

X115R FUEL WATER SEPARATOR / CATCHCAN FITMENT INSTRUCTIONS

MITSUBISHI TRITON MN 2.5ltr - See RYCO catalogue for specific application details.

The Ryco X115R kit includes mounting bracket specifically designed for the vehicle, and all components required to complete the installation of Ryco Z980SK16 series fuel water separator and RCC351 series catchcan (both included in this kit). It is recommended that the installation is conducted by a qualified mechanic following the procedures in this instruction sheet.

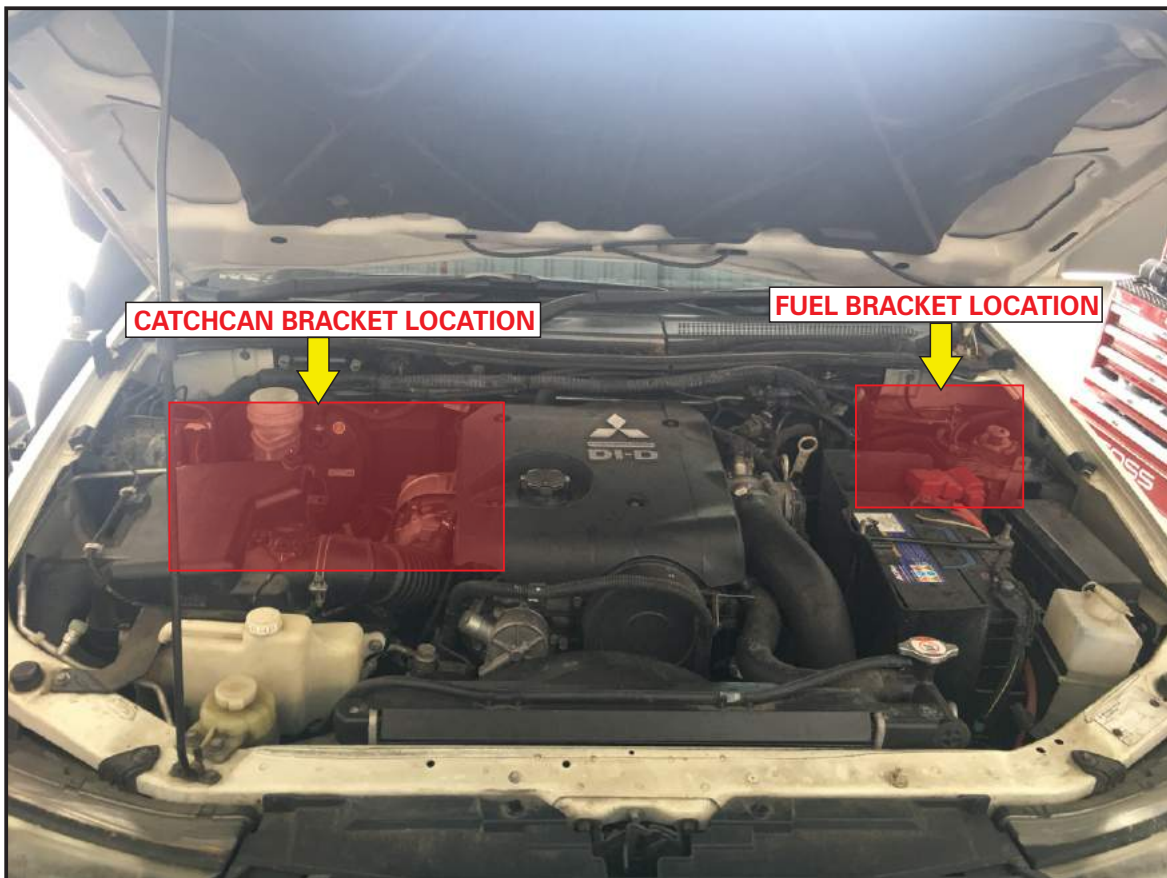

**SECTION 2
FUEL WATER SEPARATOR**

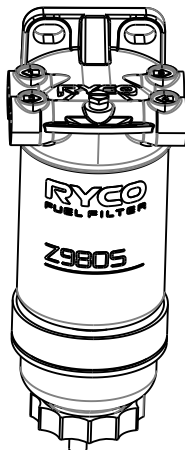

**SECTION 4
CATCHCAN**

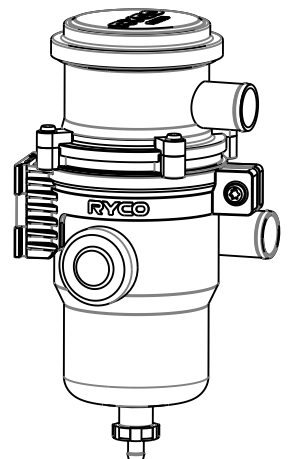

**SECTION 1
FUEL MOUNTING BRACKET**

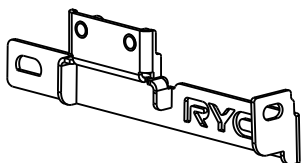

**SECTION 3
CATCHCAN MOUNTING BRACKET**

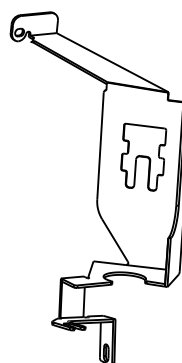

**COMPONENTS INCLUDED IN X115R KIT
(Components not sold SEPARATELY)**

X115R PARTS LIST - FUEL FILTER BRACKET & COMPONENTS BOX

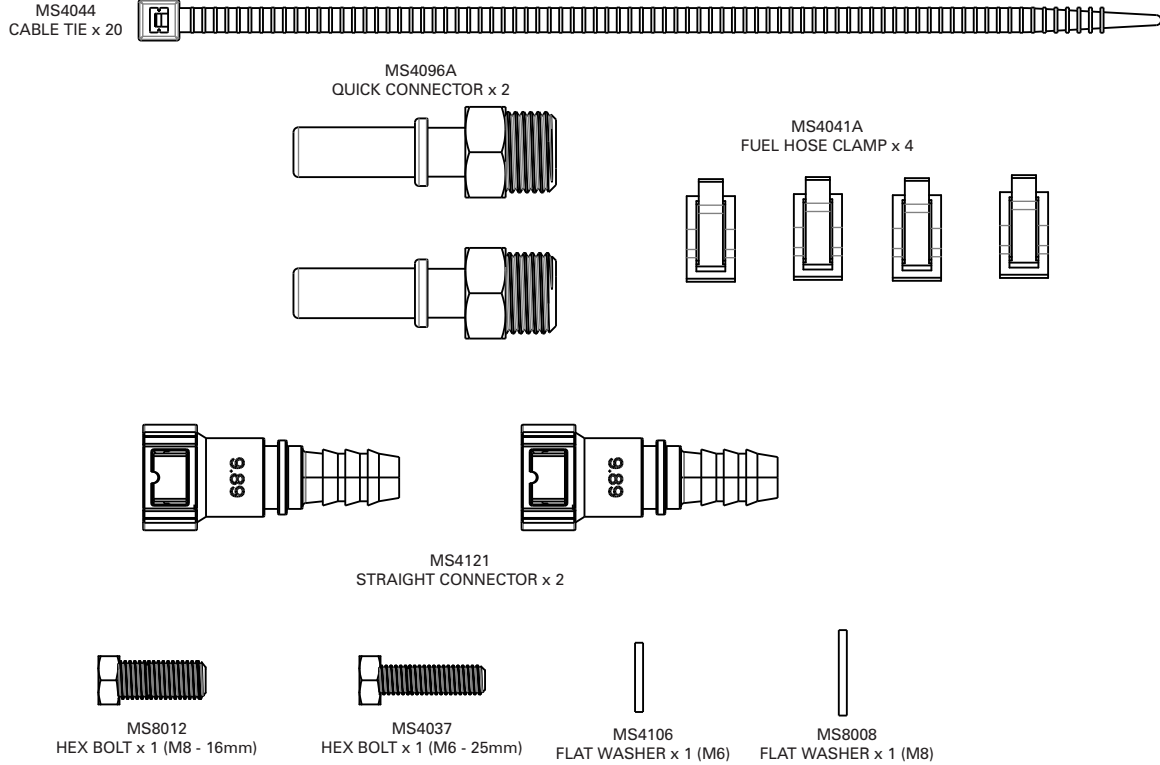

PARTS LIST - PACKAGED IN CARTON

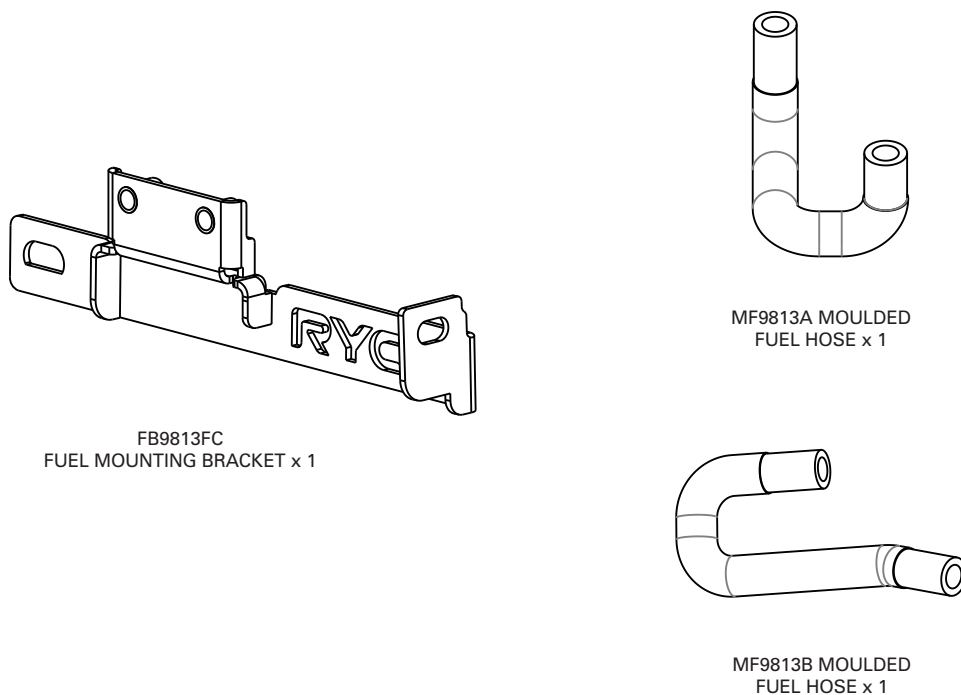

**COMPONENTS INCLUDED IN X115R KIT
(Components not sold SEPARATELY)**

X115R PARTS LIST - CATCHCAN BRACKET & COMPONENTS BOX

MS4089
PVC HOSE x 1M

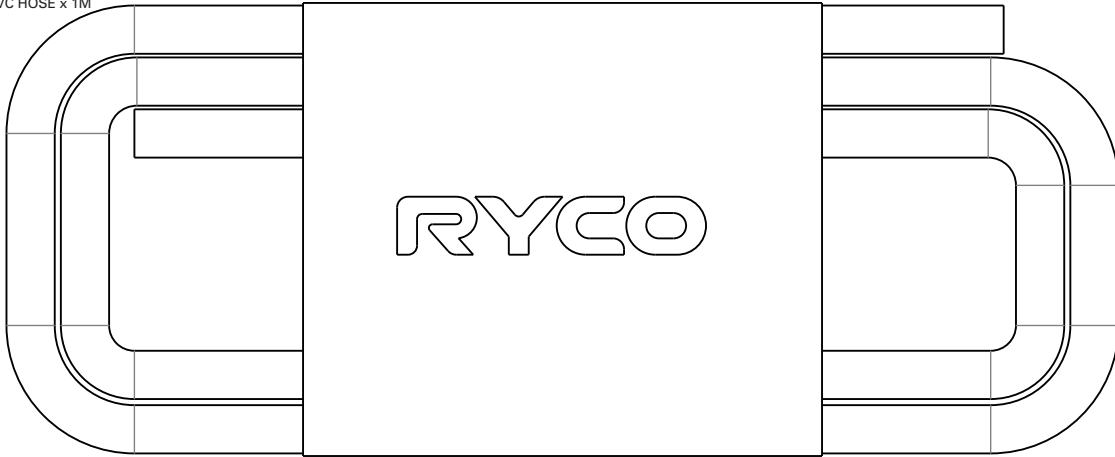

MS4091
PCV HOSE CLAMP x 2

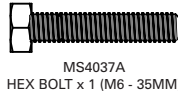
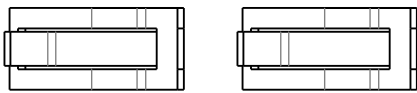

MS4037A
HEX BOLT x 1 (M6 - 35MM)



MS4106
FLAT WASHER x 2 (M6)

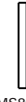

MS8008
FLAT WASHER x 1 (M8)



MS4040
FLANGE NUT x 1 (M6)

MS4092
PCV HOSE CLAMP x 2

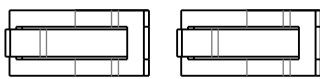

MS4107
SPRING WASHER x 1 (M6)



MS4093
DRAIN HOSE CLAMP x 2

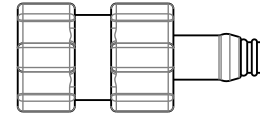

MS4090
DRAIN VALVE x 1

PARTS LIST - PACKAGED IN CARTON

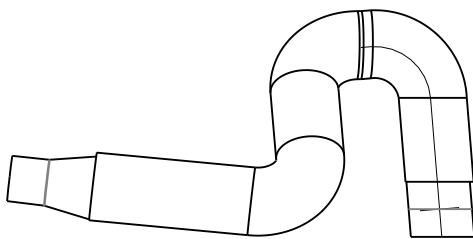

MH9813A
PCV HOSE x 1

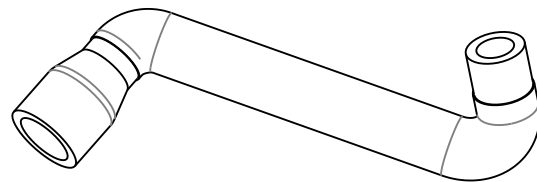



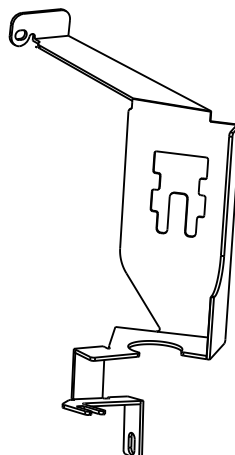

MH9813B
PCV HOSE x 1

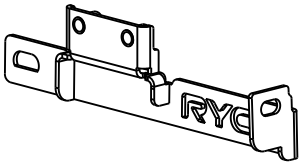

FB9813CC
CATCHCAN MOUNTING BRACKET x 1

X115R FUEL WATER SEPARATOR FITMENT INSTRUCTIONS

SECTION 1 FUEL MOUNTING BRACKET FITMENT (1/2)

PARTS REQUIRED		TOOLS & PPE'S REQUIRED
 <p>FB9813FC FUEL MOUNTING BRACKET</p>	 <p>MS8012 HEX BOLT x 1 (M8 - 16mm)</p>  <p>MS4037 HEX BOLT x 1 (M6 - 25mm)</p>  <p>MS4106 FLAT WASHER x 1 (M6)</p>  <p>MS8008 FLAT WASHER x 1 (M8)</p>	<p>* WORK GLOVES * SOCKET SET * RATCHET SET</p>

WORK PROCEDURE



M8 Engine Bay Thread

FIG. 1B M8 THREAD LOCATION



M6 Engine Bay Thread

FIG. 1C M6 THREAD LOCATION



FIG. 1A FUEL INSTALLATION AREA

1. Please note above diagrams for engine bay thread locations used for fitting FB9813FC fuel bracket.

X115R FUEL WATER SEPARATOR FITMENT INSTRUCTIONS

SECTION 1 FUEL MOUNTING BRACKET FITMENT (2/2)

WORK PROCEDURE

2. Note Fitment Location of FB9813FC

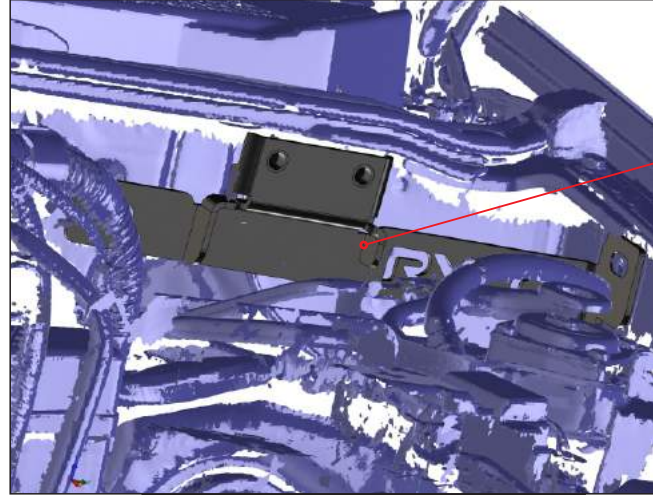

FB9813FC

FIG. 2 FB9813FC BRACKET PLACEMENT

3. Attach MS8008 M8 flat washer to M8 Hex Bolt MS8012, then screw M8 Hex Bolt into M8 engine bay thread as shown in Fig.3 .

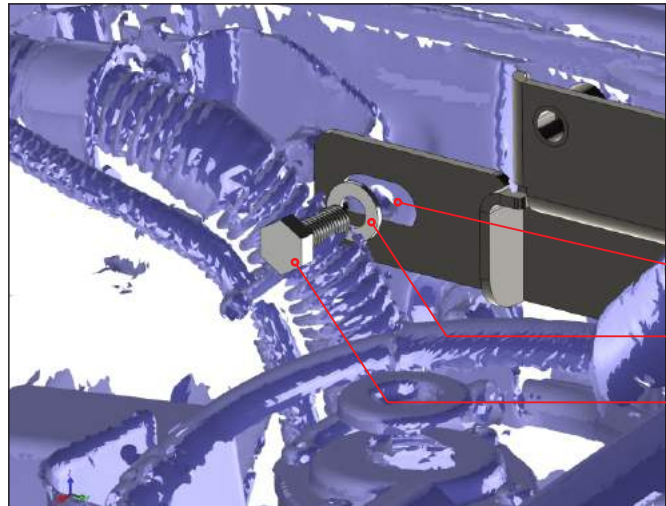

M8 Engine Bay Thread

MS8008 M8 Washer

MS8012 M8 Hex Bolt

FIG. 3 M8 THREAD LOCATION

4. Attach MS4106 M6 flat washer to M6 Hex Bolt MS4037, then screw M6 Hex Bolt into M6 engine bay thread as shown in Fig.4 .

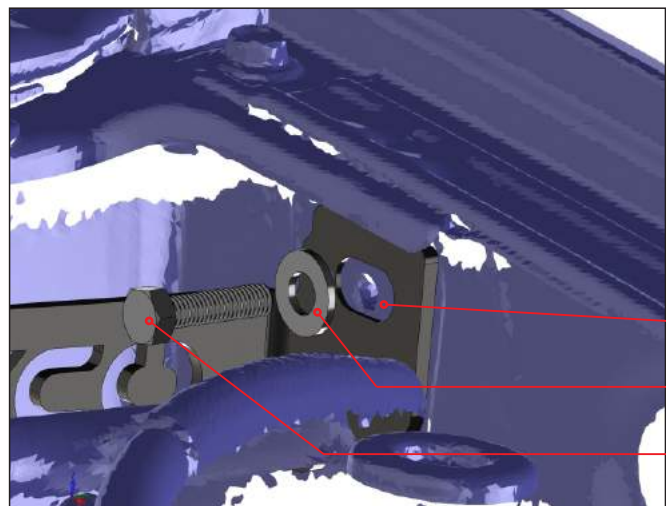

M8 Engine Bay Thread

MS8008 M8 Washer

MS8012 M8 Hex Bolt

FIG. 4 M6 THREAD LOCATION

X115R FUEL WATER SEPARATOR FITMENT INSTRUCTIONS

SECTION 2 FUEL WATER SEPARATOR INSTALLATION (2/4)

5. Referring to FIG.7A/B, remove OEM fuel house that is connected between "from fuel tank" metal pipe & "OEM fuel filter housing inlet" metal pipe.

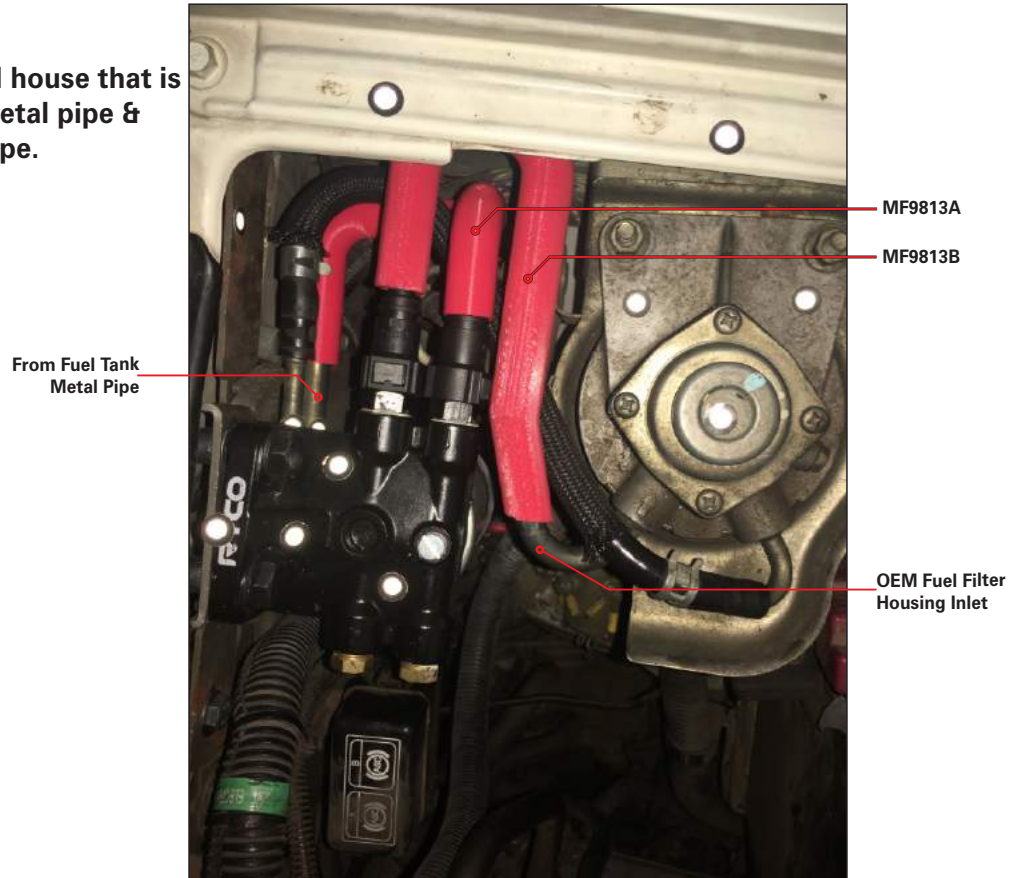

FIG. 7A FUEL HOSE FITMENT

6. Referring to Fig.7B install assembled fuel hoses MF9813A and MF9813B as shown. MF9813A connects to "from fuel tank" metal pipe. MF9813B connects to OEM fuel filter housing inlet metal pipe.

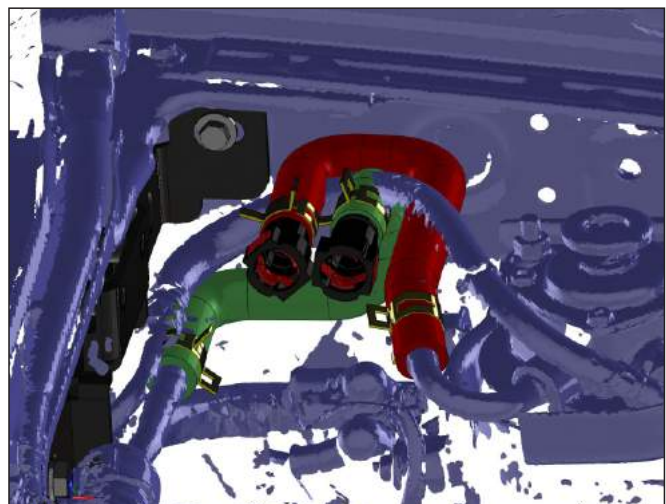

FIG. 7B FUEL HOSE FITMENT

X115R FUEL WATER SEPARATOR FITMENT INSTRUCTIONS

SECTION 2 FUEL MOUNTING BRACKET FITMENT (3/4)

WORK PROCEDURE

7. Using the M10 Bolts and Washers supplied in the Ryco Z980SK16 fuel water separator kit, attach the Z980SK16 to the FB9813FC bracket as shown in FIG. 6.
8. Starting with the longer Ryco fuel hose MF9813A, install the Straight connector end onto the inlet port on the Ryco fuel filter head. Then proceed to fit the straight connector end of MF9813B onto the outlet port of the Ryco fuel filter head.
Connection has been successfully made when you hear a 'click' noise.

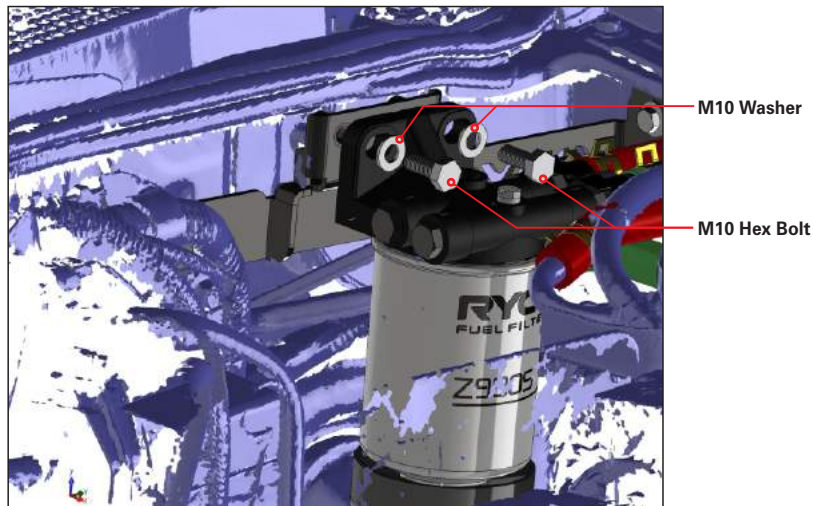

FIG. 8 FILTER HEAD FITMENT

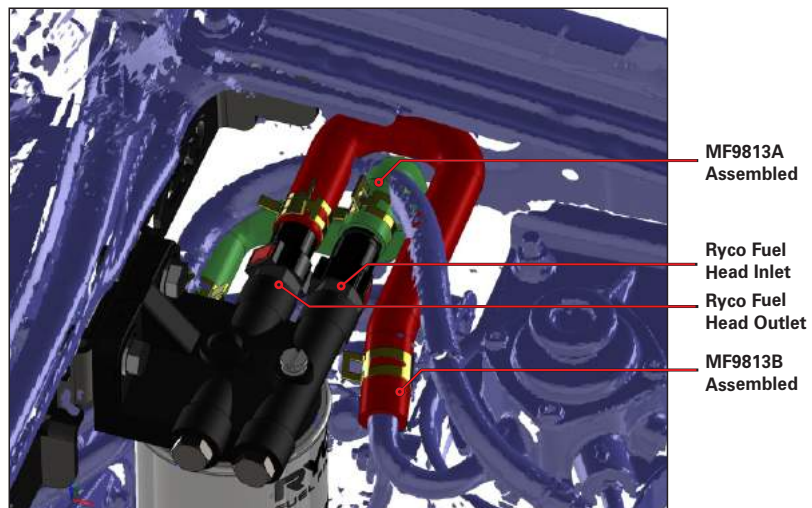

FIG. 9 HOSE FITMENT TO FILTER HEAD

X115R FUEL WATER SEPARATOR FITMENT INSTRUCTIONS

SECTION 2 FUEL MOUNTING BRACKET FITMENT (4/4)

REFER TO FIG.7 DIAGRAM BELOW

9. **WARNING:** The fuel system **MUST BE PRIMED** prior to starting the engine.
DO NOT OPEN THE BLEED SCREW ON THE RYCO Z980SK16, keep closed.
10. Locate the priming button on top of the factory fuel filter and prime the fuel system by pumping the button repeatedly. Continue pumping until it is hard to press.
The priming process could take approximately 5 - 10 minutes.
11. Once you can no longer depress the priming button, turn on the engine.
With the engine running, check for fuel leaks on all the installed equipment.

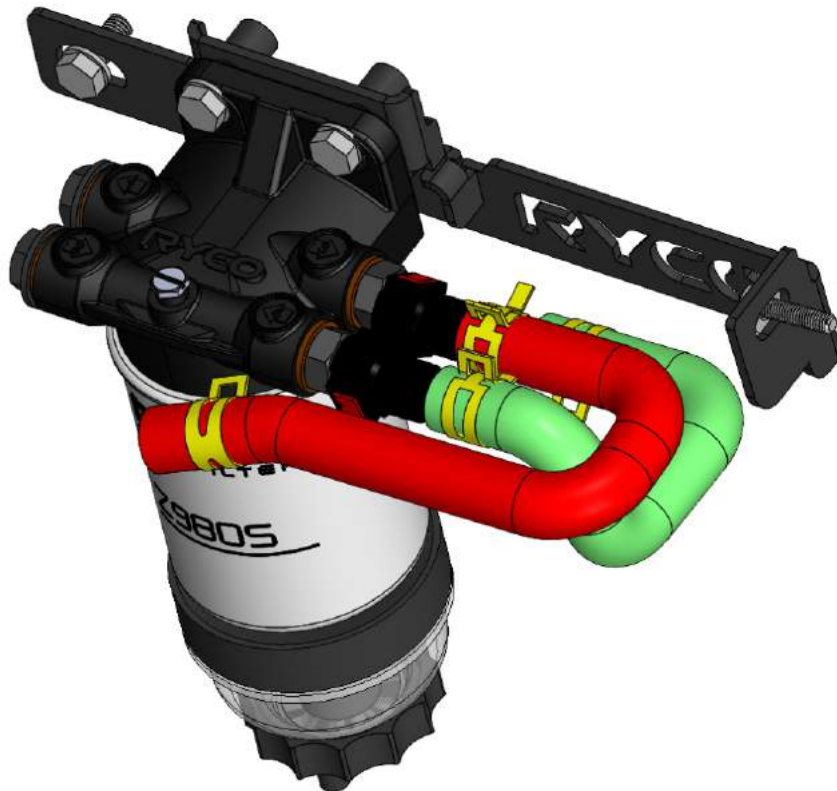

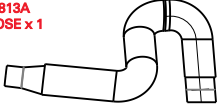

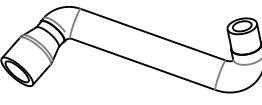







FIG. 10 COMPLETED FUEL BRACKET INSTALLATION.

X115R CATCHCAN FITMENT INSTRUCTIONS

SECTION 3 CATCHCAN INSTALLATION (1/6)

PARTS REQUIRED		TOOLS & PPE'S REQUIRED		
 <p>RCC351 CATCHCAN</p>	<p>MH9813A PCV HOSE x 1</p> 	<p>MS8008 FLAT WASHER x 1 (M8)</p> 	<p>* WORK GLOVES * RACHET SET * HOSE CLAMP PLIERS</p>  <p>FB9813CC CATCHCAN MOUNTING BRACKET x 1</p>	
	<p>MH9813B PCV HOSE x 1</p> 	<p>MS4037A HEX BOLT x 1 (M6 - 35MM)</p> 		<p>MS4106 FLAT WASHER x 2 (M6)</p> 
	<p>MS4091 PCV HOSE CLAMP x 2</p> 	<p>MS4107 SPRING WASHER x 1 (M6)</p> 		<p>MS4040 FLANGE NUT x 1 (M6)</p> 
	<p>MS4092 PCV HOSE CLAMP x 2</p> 			

WORK PROCEDURE

1. Remove the plastic engine cover.
2. Remove OEM PCV hose highlighted green in FIG. 12



FIG.11 ENGINE COVER REMOVED



FIG.12 OEM PCV HOSE REMOVAL

X115R CATCHCAN FITMENT INSTRUCTIONS

SECTION 3 CATCHCAN INSTALLATION (2/6)

3. Remove air box bolt & M8 OEM bolt shown in FIG.13
Ensure M8 OEM bolt is kept as this will be reused in later steps.



FIG. 13 AIR BOX BOLT REMOVAL

4. Remove plastic clip from stud shown in FIG. 14 & 15.



FIG. 14 PLASTIC CLIP LOCATION



FIG. 15 PLASTIC CLIP REMOVED

X115R CATCHCAN FITMENT INSTRUCTIONS

SECTION 3 CATCHCAN INSTALLATION (3/6)

5. Referring to FIG.16 & 17, fit FB9813CC Ryco catchcan bracket as shown.

NOTE: you will need to maneuver leg of catchcan bracket around metal piping for fitment, as shown in FIG. 17.



FIG. 16 FB9813CC FITMENT LOCATION, FRONT OF CAR VIEW



FIG. 17 FB9813CC FITMENT LOCATION, BEHIND AIR BOX VIEW



MS4037A M6 Bolt
with washers attached
bolted into air box
mount

FIG. 18 RYCO AIR BOX BOLT & WASHERS FITTED

X115R CATCHCAN FITMENT INSTRUCTIONS

SECTION 4 CATCHCAN INSTALLATION (4/6)

6. Attach first MS4107 M6 spring washer and then MS4106 M6 washer to MS4037A M6 bolt. Screw in M6 bolt with washers attached into air box mount thread as shown in FIG.18 & 19A. Using OEM M8 bolt previously removed, attach MS8008 M8 washer, then screw in OEM M8 bolt as shown in FIG.19A.

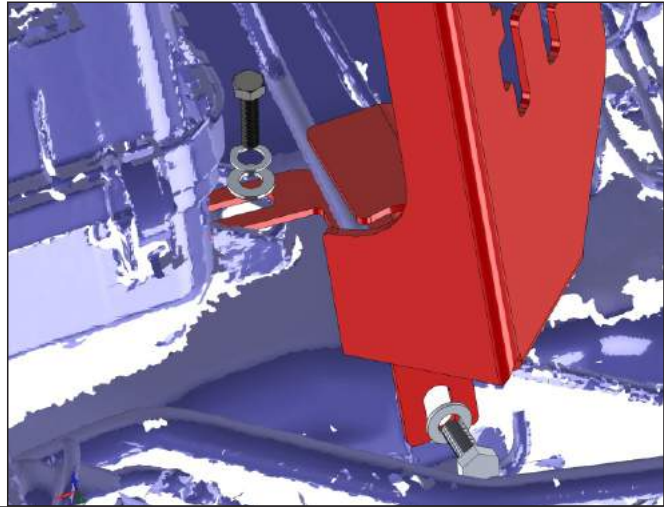

FIG. 19A BOLT AND WASHER FITMENT TO CATCHCAN BRACKET

7. Attach first MS4107 M6 spring washer to OEM stud shown in FIG.19B. Then screw on MS4040 M6 flange nut.



FIG. 19B BOLT AND WASHER FITMENT TO CATCHCAN BRACKET

8. Slot Catchcan onto bracket in orientation shown in FIG.20.



FIG. 20 CATCHCAN FITTED TO CATCHCAN BRACKET

X115R CATCHCAN FITMENT INSTRUCTIONS

SECTION 4 CATCHCAN INSTALLATION (5/6)

REFER TO FIG. 21 & 22

9. Starting with the MH9813A PCV hose, install the small end on to the Engine PCV Port & tighten with the MS4094 hose clamp as shown in Fig. 22.

13. Install the other end of the MH9813A PCV hose on to the lower, inlet port, of the RCC351 Catchcan and tighten with the MS4091 hose clamp as shown in Fig. 22.

14. Install the larger end of the MH9813B PCV hose on to the upper, outlet port, of the RCC351 Catchcan and tighten with a MS4091 hose clamp. Install the other end of the MH9813B PCV hose on to the Air Intake PCV port and tighten with a MS4094 hose clamp as shown in Fig. 22.

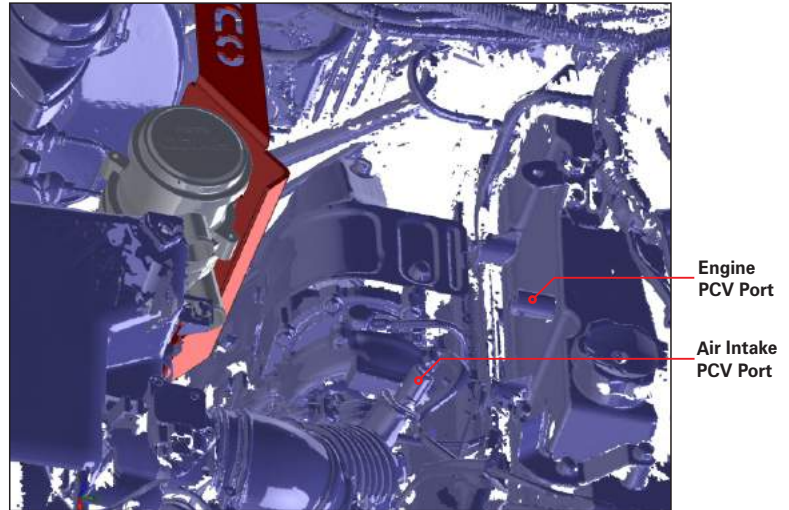

FIG. 21 PCV CONNECTION LOCATIONS

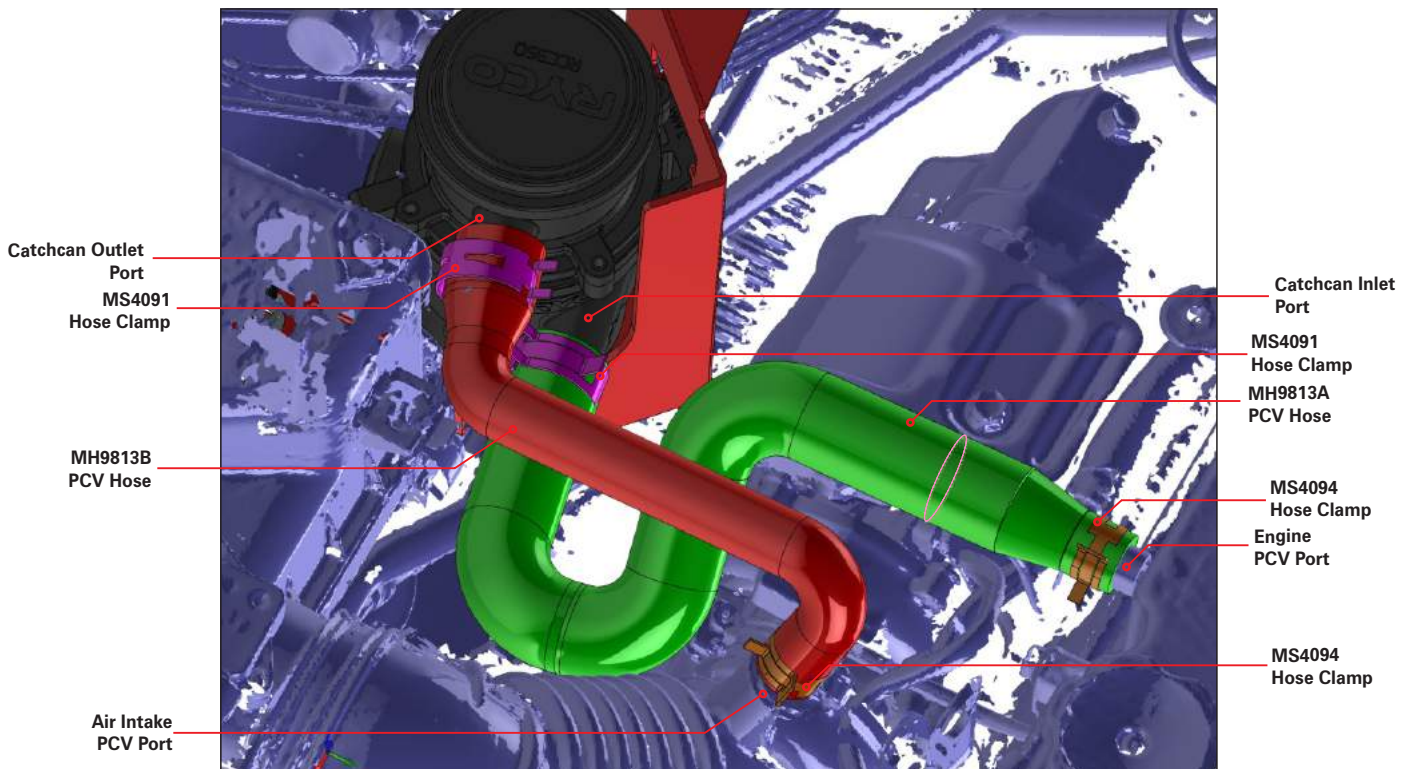

FIG. 22 PCV HOSE FITMENT

X115R CATCHCAN FITMENT INSTRUCTIONS

SECTION 4 CATCHCAN INSTALLATION (6/6)

DRAIN HOSE INSTALLATION PROCEDURE (OPTIONAL)

1. To install the drain hose, remove the drain plug from the bottom of RCC351, take out the rubber seal from the plug and refit. Insert the drain hose and secure it with the supplied spring clamp. Insert the hose drain tap to the other end and use the zip ties to secure the hose. To drain, pull back the red section until all oil has drained out.
2. If it has been fitted without using the drain hose supplied, simply slide out the unit from its bracket and remove the drain plug on the unit and let the oil drain onto a pan or bottle.

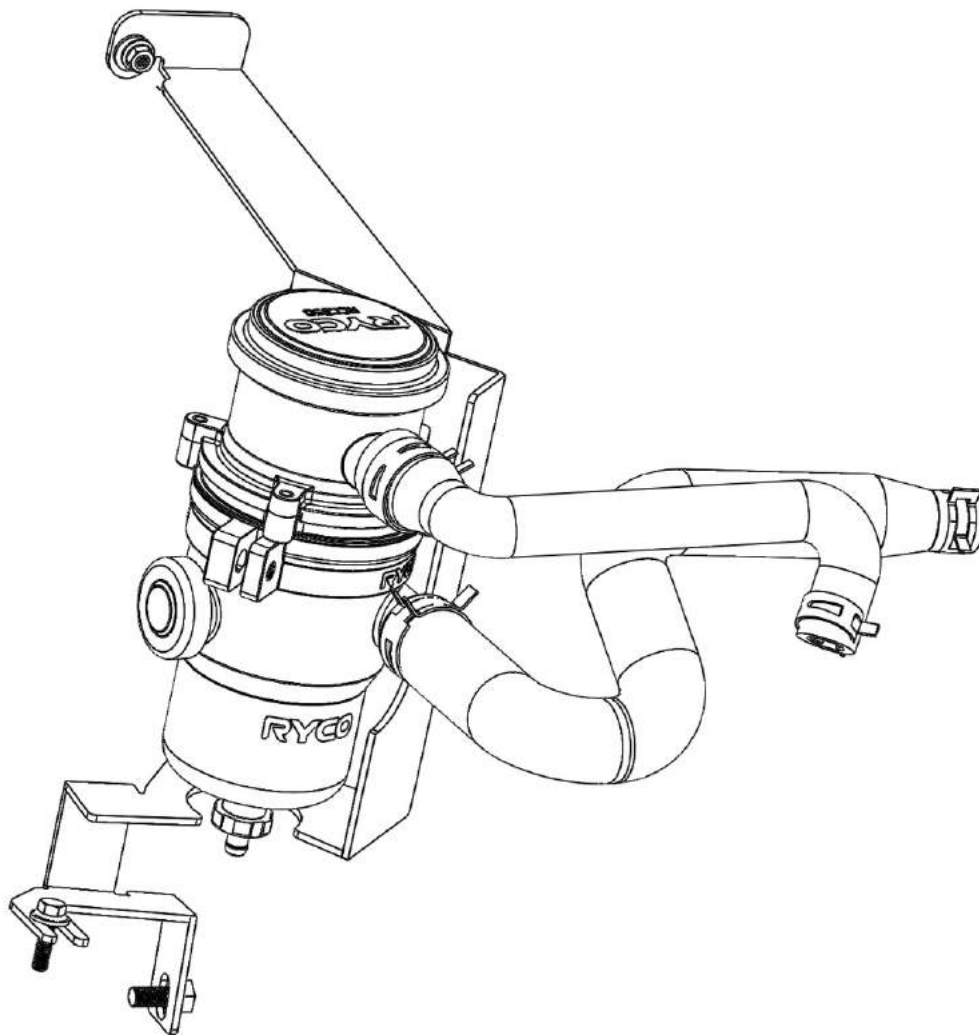

AUSTRALIA
RYCO Group Pty Ltd
29 Taras Avenue, Altona North
Victoria 3025 Australia.
www.rycofilters.com.au

NEW ZEALAND
RYCO Group - A division of GUD (NZ) Holdings Limited
19 Bell Avenue, Otahuhu,
Auckland, 1060 New Zealand.
www.ryco.co.nz

SOCIAL NETWORKS
Facebook: <http://facebook.com/rycofilters>
YouTube: <http://youtube.com/rycofilters1>
Twitter: http://twitter.com/Ryco_Filters
Instagram: <http://instagram.com/rycofilters>