

# RYCO

## X114R™

### FUEL WATER SEPARATOR / CATCH CAN FITTING INSTRUCTIONS



RYCOFILTERS.COM.AU | RYCO.CO.NZ

**BE**  
**RYCO**  
**READY**

**FORD RANGER RAPTOR / EVEREST** See Ryco catalogue for specific application details.

The Ryco X114R kit includes mounting bracket specifically designed for the vehicle, and all components required to complete the installation of Ryco Z980K16 series fuel water separator and RCC360 series catch can. It is recommended that the installation is conducted by a qualified mechanic following the procedures in this instruction sheet.

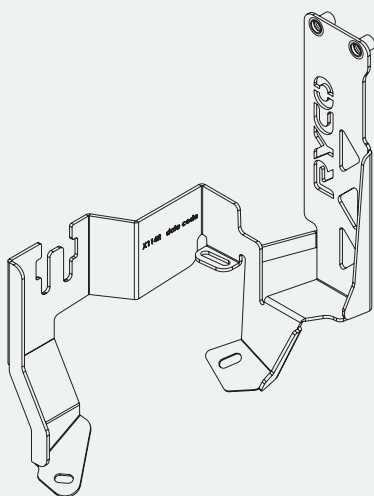
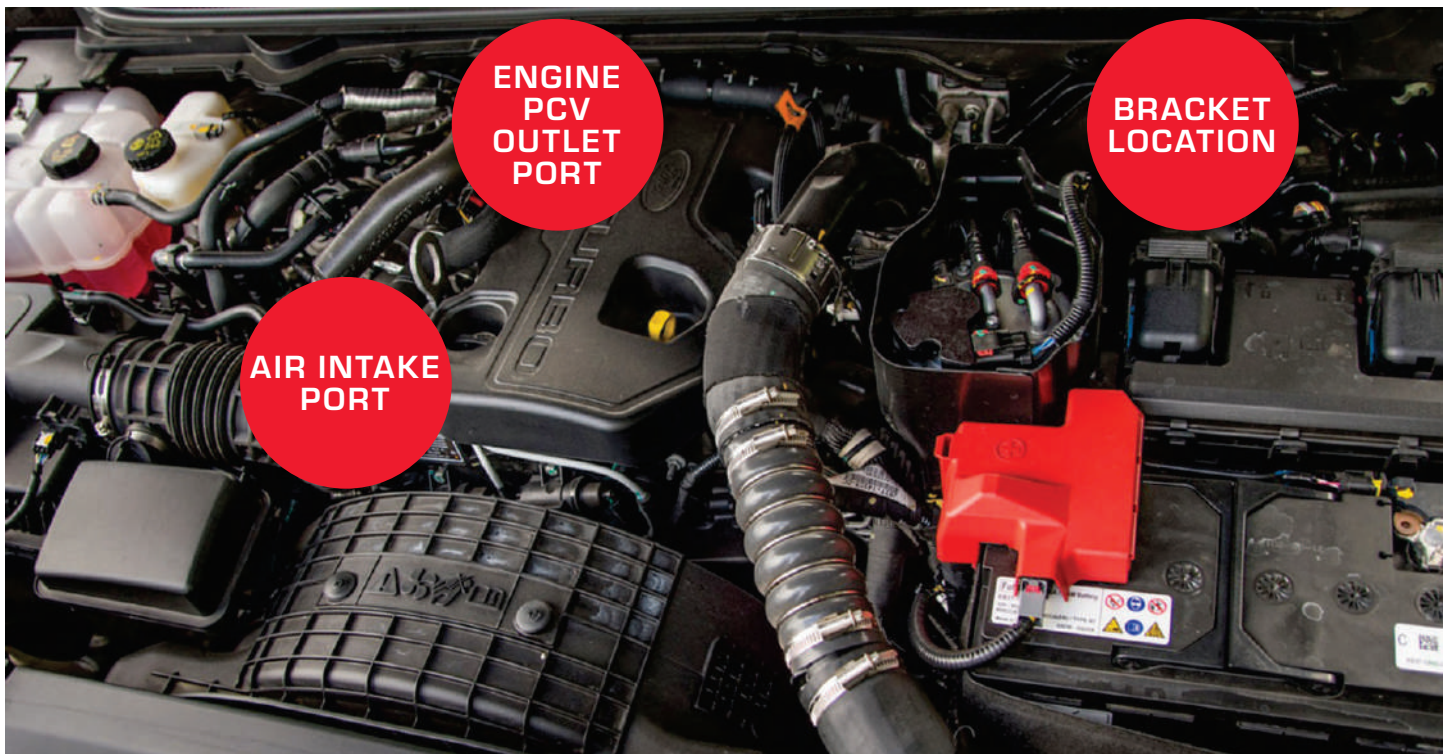

**SECTION 1**  
METAL BRACKET

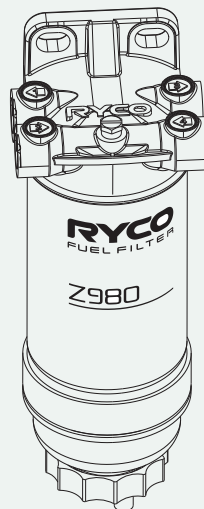

**SECTION 2**  
FUEL WATER SEPARATOR

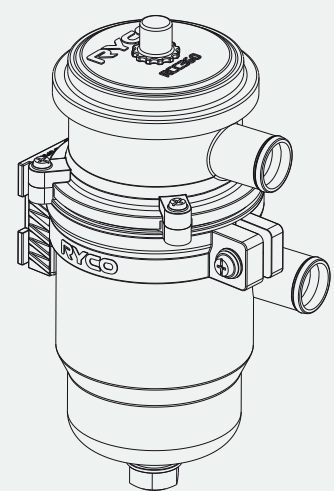

**SECTION 3**  
CATCH CAN

### COMPONENTS INCLUDED IN X114R KIT

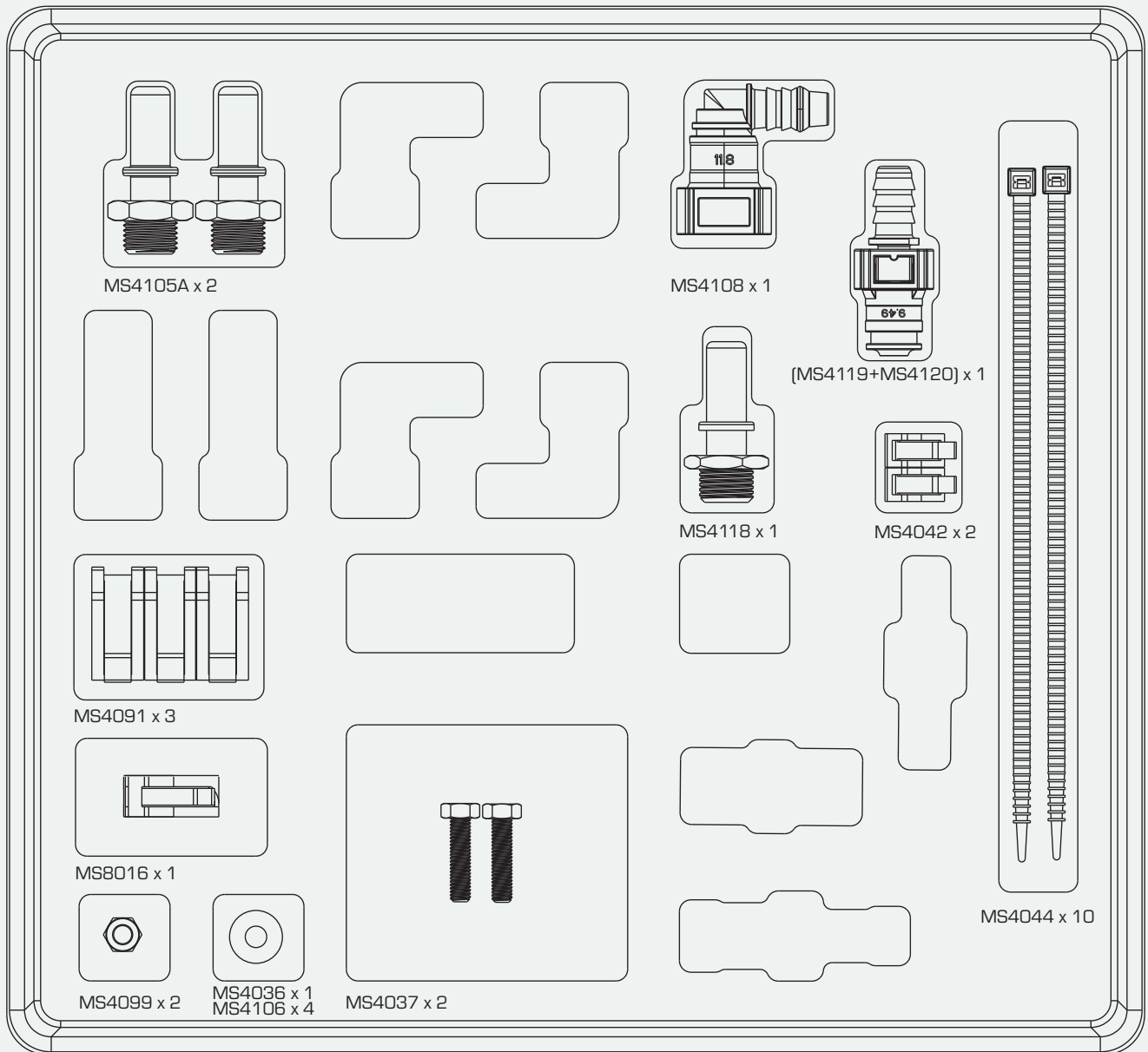

### COMPONENTS INCLUDED IN X106R KIT

FUEL WATER SEPARATOR  
MOUNTING POSITION

CATCH CAN  
MOUNTING POSITION

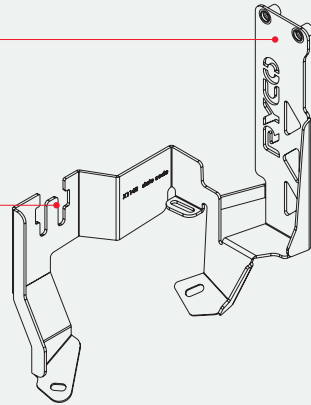

FB9803X  
MOUNTING BRACKET x 1

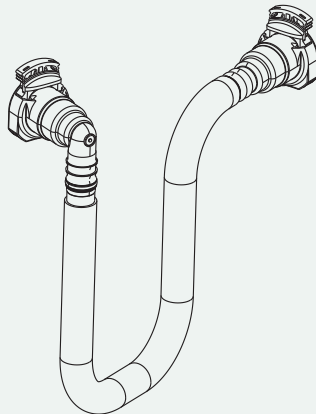

MF9803 ASSY  
FUEL HOSE x 1

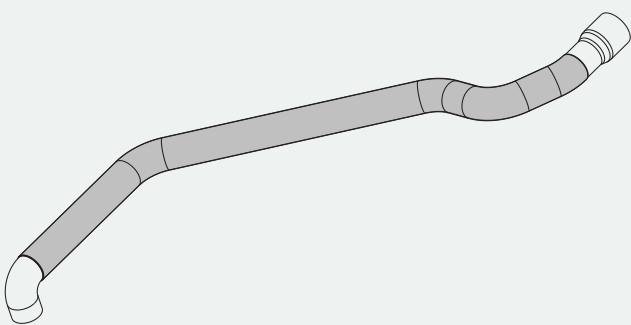

MH9812A  
PCV HOSE x 1

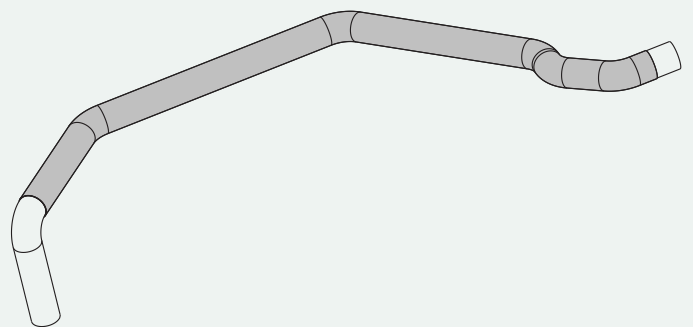

MH9812B  
PCV HOSE x 1

### SECTION 1 METAL BRACKET FITMENT

#### PARTS REQUIRED

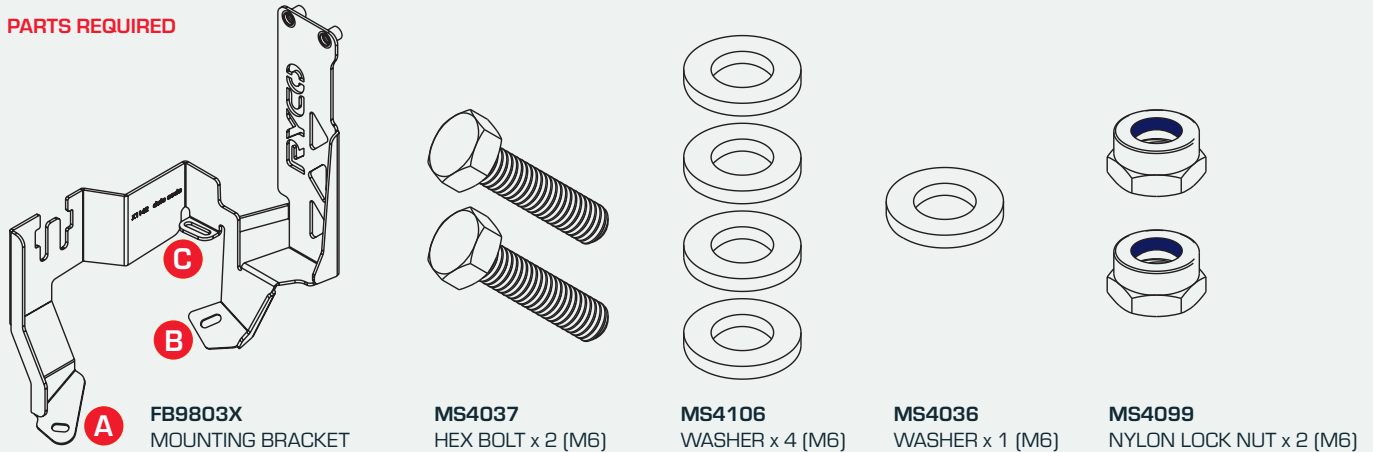

#### TOOLS & PPE REQUIRED

- Ratchet Set
- Work Gloves

#### WORK PROCEDURE

- 1 Remove the factory M6 nut on the fuse box from Point "C".
- 2 Position the bracket in the engine bay as per Figure 1, placing Point "A" at the rear hole on the front-left wheel house of the vehicle, placing Point "B" at the front hole and Point "C" at the fuse box stud.
- 3 Loosely refit the factory M6 nut with washer MS4036 at Point "C" onto the fuse box stud.
- 4 Note the position of the hole at Point "A". From the front-left wheel house of the vehicle, install the supplied M6 bolt MS4037 with washer MS4106 upwards through the hole at Point "A", and secure the bracket with the M6 nut MS4099 and another M6 washer MS4106.  
[Caution: Note the bolt direction. Do not install the bolt so it protrudes into the wheel house].
- 5 Repeat same installation at Point "B".
- 6 Tighten fasteners at Point "A" first, watching the clearance of the bracket with the "FUSE BOX". Second tighten fasteners at Point "B", watching the clearance of the bracket with the "OEM Filter Assemblies". Finally to tighten the fasteners at Point "C" (as per Figure 2).

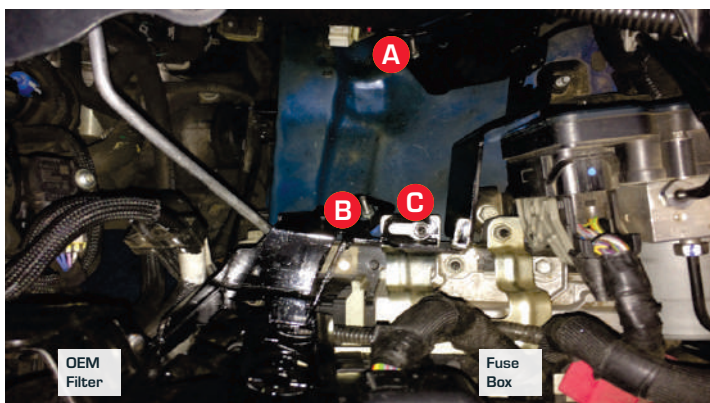

FIGURE 1  
BRACKET IN ENGINE BAY

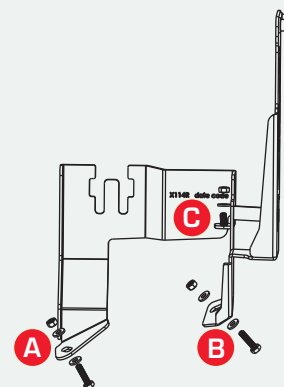
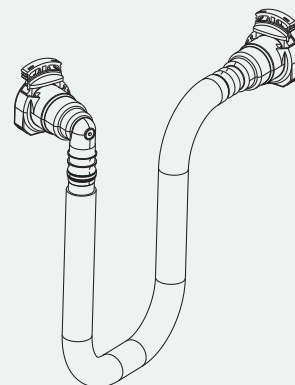
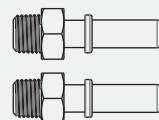
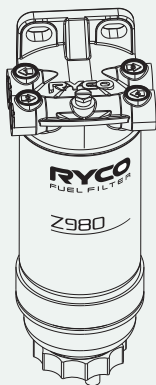
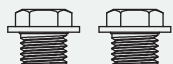
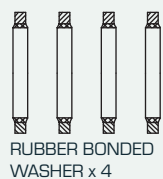

FIGURE 2  
BRACKET INSTALLATION

### SECTION 2 FUEL WATER SEPARATOR INSTALLATION

#### PARTS REQUIRED



#### TOOLS & PPE REQUIRED

- Ratchet Set
- Work Gloves
- Hose Clamp Pliers
- Rags

#### WORK PROCEDURE

- 1 Install the Ryco fuel water separator head with metal quick connectors, blanking plugs and rubber bonded washers, as per Figure 3. Tighten blanking plugs (port 1 & 2) and quick connectors (port 3 & 4).
- 2 Check the supplied Nylon fuel hose assembly with elbow and straight, as per Figure 4.

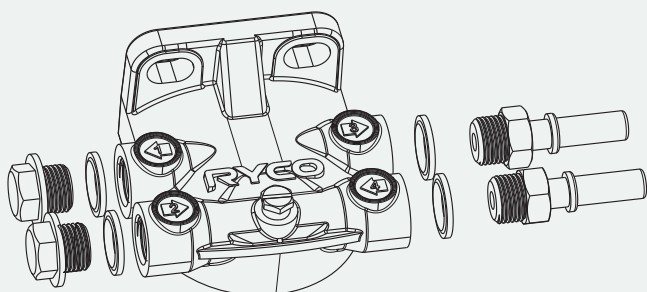

FIGURE 3  
FUEL WATER SEPARATOR HEAD PREPARATION

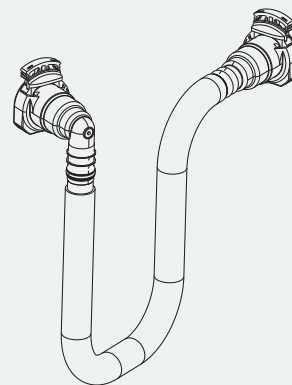

FIGURE 4  
NYLON FUEL HOSE ASSEMBLY

### SECTION 2 FUEL WATER SEPARATOR INSTALLATION CONTINUED

#### WORK PROCEDURE CONTINUED

- 3 Mount Z980K16 assembly onto the metal bracket using the two (2) black M10 bolts supplied with the Z980K16.
- 4 Locate the factory fuel supply line by starting at the factory fuel filter. Locate the inlet straight red connector (see Figure 5), pull up the locking tab, then press the release button and pull back to remove. Have a rag ready to capture any diesel that may spill out of the fuel line and the fuel filter.
- 5 The factory fuel supply line is a pre-formed nylon tube. Carefully thread it back, down and out from the factory fuel filter bracket. Position it on the engine side of the air conditioning pipe and plug it in to the inlet quick connect port 4 on the Z980K16. Ensure the locking tab is engaged. Check the fuel pipe routing to ensure it's not kinked and re-position if necessary. (See Figure 6)
- 6 Connect the supplied Nylon hose to the outlet port 3 of the Z980K16 (coloured yellow in Figure 6) by pushing the elbow connector onto the metal quick connector until you hear a "click". Then push down the locker.
- 7 Route the hose as shown in Figure 6, up and through the factory fuel filter bracket. Pushing the straight connector onto the factory fuel filter inlet port until you hear a "click". Then push down the locker.
- 8 Make sure all hoses are tightened.
- 9 Find an assistant to help prime the fuel system. Place a container under the unconnected straight connector. Prime the fuel system by turning the ignition key to "On / Run" position (do not start the Engine) until fuel comes out from the straight connector. Turn off the ignition and connect the elbow connector to the factory fuel filter inlet port by pushing it all the way on until you hear a "click". Start the engine and check for leaks in fuel lines and connectors.

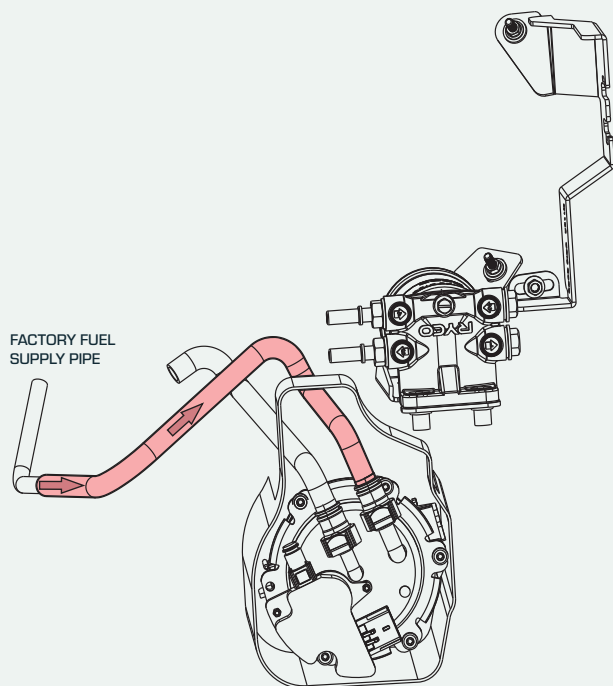

FIGURE 5  
FACTORY HOSE IDENTIFICATION

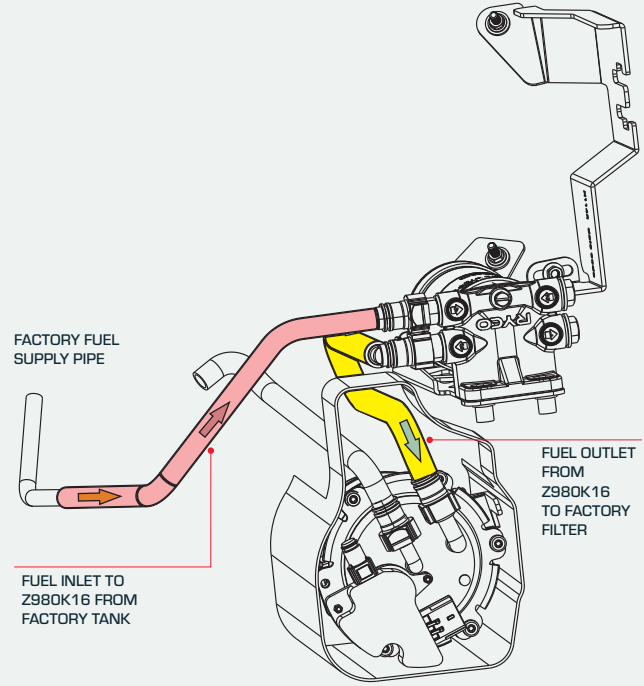
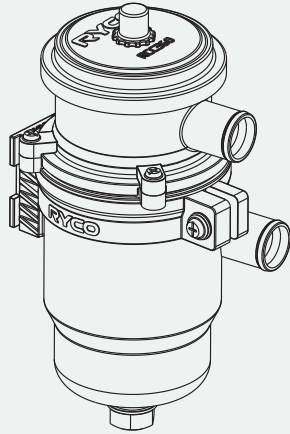

FIGURE 6  
FUEL WATER SEPARATOR & FUEL HOSE INSTALLATION

### SECTION 3 CATCH CAN INSTALLATION

#### PARTS REQUIRED



RCC360  
CATCH CAN

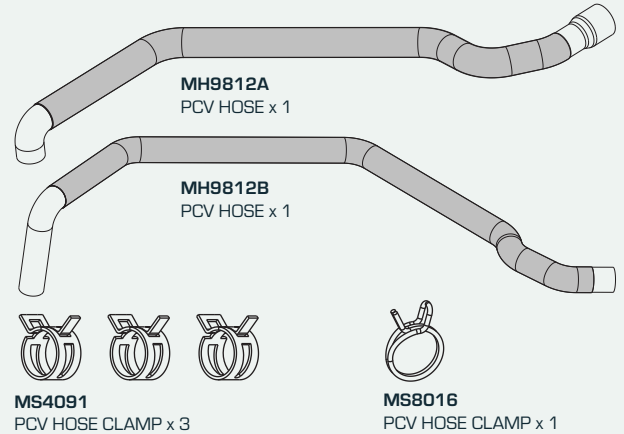

MS4091  
PCV HOSE CLAMP x 3

MS8016  
PCV HOSE CLAMP x 1

#### TOOLS & PPE REQUIRED

- Ratchet Set
- Work Gloves
- Hose Clamp Pliers

#### WORK PROCEDURE

- 1 Remove the engine cover.
- 2 Mount the catchcan onto the bracket by sliding the RCC360 nylon bracket onto the catchcan mounting position on the bracket, rotate it so it is facing directly toward the engine and tighten the plastic bracket retaining screw.
- 3 Remove factory PCV hose by lifting the locking collars and pulling upwards. The PCV hose is connected to the PCV valve located at the top of the engine at rear drivers side corner, and to the air intake towards the front of the engine bay as per Figure 7 below.



FIGURE 7  
FACTORY PCV HOSE



### SECTION 3 CATCH CAN INSTALLATION CONTINUED

#### WORK PROCEDURE CONTINUED

- 4 Connect the smaller end (19mm) of the MH9812A Ryco moulded hose (shown blue in Figure 8) to the engine PCV valve outlet and secure with a supplied hose clamp. Feed the hose behind the engine, under the other engine pipes and around the AC pipes and connect the larger end (25mm) of the moulded hose to the lower port of the RCC360 with one of the large PCV hose clamps. Use Figure 9 as a guide.
- 5 Feed MH9812B Ryco moulded hose (shown green in Figure 8) along the top of the first hose ensuring it runs over the factory pipes including the AC pipes. Connect one end to the upper port of the RCC360, securing with a large PCV hose clamp. Connect the other in to the engine PCV air intake port and secure with a PCV hose clamp (Figure 8).
- 6 Check both PCV hoses are not jammed or kinked by the surrounding engine parts. Refit the engine cover.

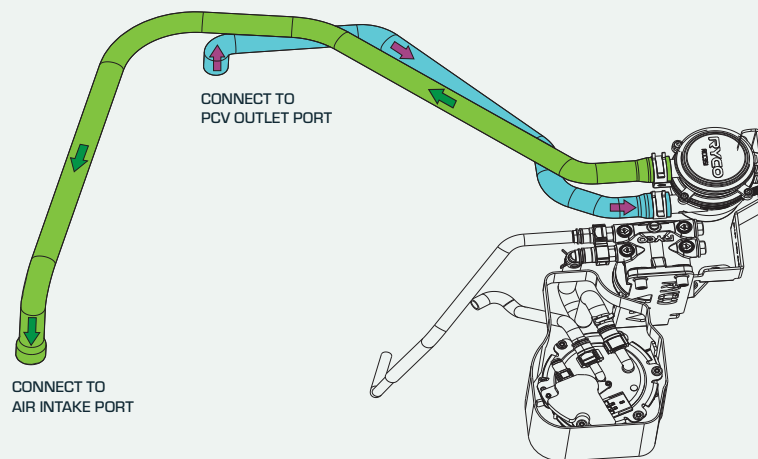

FIGURE 8  
CATCH CAN INSTALLATION

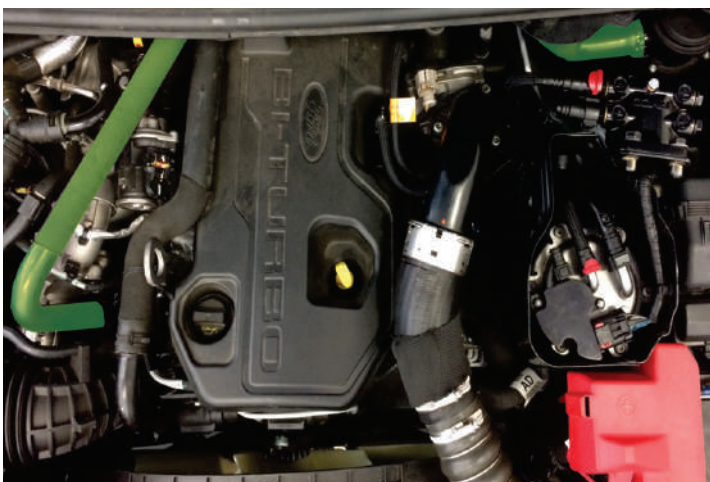
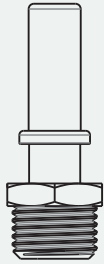

FIGURE 9  
CATCH CAN HOSE LAYOUT



### INCLUDED DRAIN HOSE COMPONENTS



**MS4118**  
QUICK CONNECTOR x 1

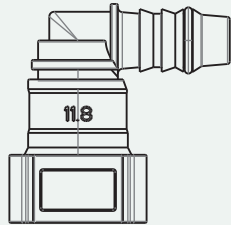

**MS4108**  
ELBOW QUICK CONNECTOR x 1

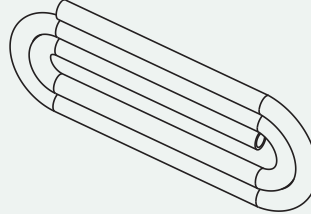

**MS4117**  
PVC HOSE x 1M



**MS4119+MS4120**  
HOSE END PLUG x 1 SET

### DRAIN HOSE INSTALLATION PROCEDURE

#### To install the drain hose

- 1 Remove the blanking plug from the base of the catch can.
- 2 Remove the rubber washer from the blanking plug.
- 3 Fit rubber washer to the MS4118 Male Quick Connector.
- 4 Install MS4118 with rubber washer to the base of catch can.
- 5 Connect the MS4108 elbow female quick connector to the MS4118 male quick connector on the base of the catch can by pushing on until you hear a “click”.
- 6 Insert the drain hose onto the barb end of MS4108 and secure with the supplied spring clamp.
- 7 Insert the MS4119 onto the other end of the hose and secure with the supplied spring clamp.
- 8 Use the zip ties to secure the hose.

#### Drain hose installation

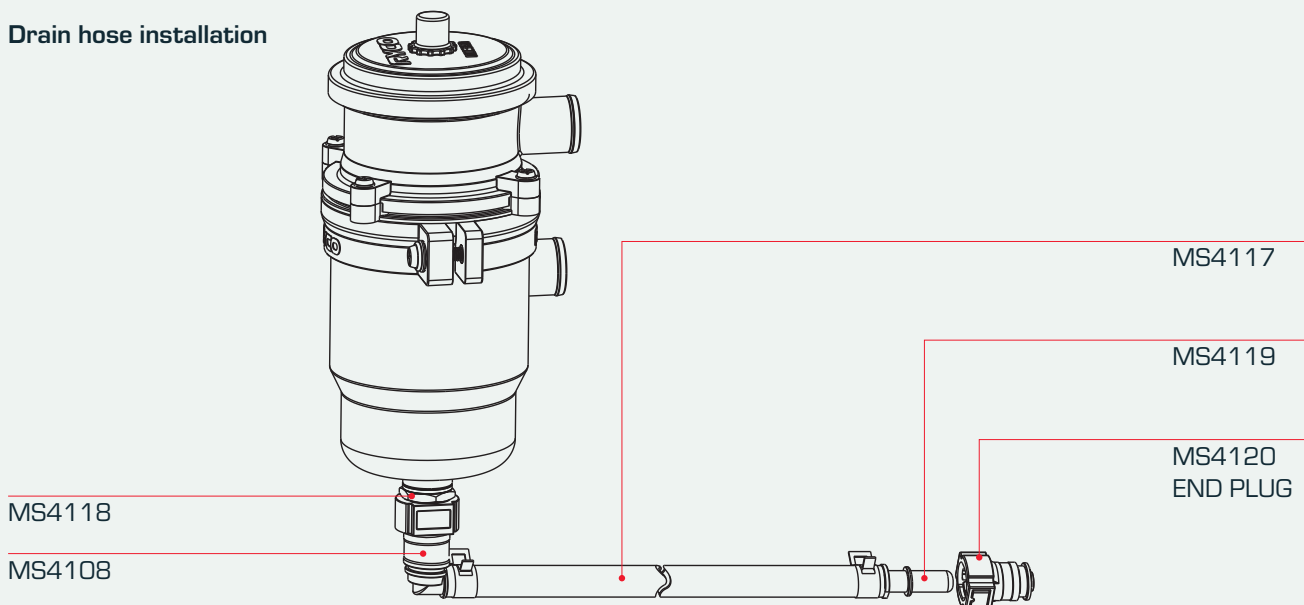

### HOW TO DRAIN THE CATCH CAN

**Note:** Check the catch can sump level every month or 5000km, whichever comes first and drain as required. Sump level checks are recommended daily when four-wheel driving or towing.

#### If the drain hose is fitted

- 1 Push both buttons on the MS4120 end plug and pull to separate from the MS4119.
- 2 Allow all oil to drain out.
- 3 Push MS4120 plug back on to MS4119 until you hear a "click".

#### If fitted without drain hose

- 1 Slide catch can out of the bracket. You may need to remove inlet and outlet hoses by loosening the hose clamps.
- 2 Remove the blanking plug from the base of the catch can.
- 3 Allow all oil to drain.
- 4 Refit the blanking plug to the base of the catch can ensure the rubber seal is in place.

### WHEN SHOULD YOU SERVICE THE CATCH CAN

#### Check service indicator

If red service indicator is not raised, the catch can does not currently require a service. Check again in a month or 5000 km. Sump level checks are recommended daily when four-wheel driving or towing. If the red service indicator is raised, unscrew the clear service indicator housing and compress the red service indicator. Run the engine and if the red service indicator raises again, it is time to service your catch can.

#### NO SERVICE REQUIRED



#### SERVICE REQUIRED



### HOW TO DRAIN THE CATCH CAN

#### How to service the catch can

- 1 Draining catch can before service is recommended
- 2 Undo the four bolts the on catch can head, take note of outlet position. Remove hoses and clamps, if required.
- 3 Separate the head from the rest of the catch can
- 4 Lift out old filter
- 5 Use a rag to clean inside catch can sump
- 6 Refit new filter (RCC160F), and replace the main housing o-ring
- 7 Reinstall the filter head noting the position of the outlet port from earlier
- 8 Tighten the four bolts and reinstall hoses and hose clamps if removed.

## X114R™

### FUEL WATER SEPARATOR / CATCH CAN FITTING INSTRUCTIONS