

X110R™

X110R FUEL WATER SEPARATOR / CATCH CAN FITMENT INSTRUCTIONS

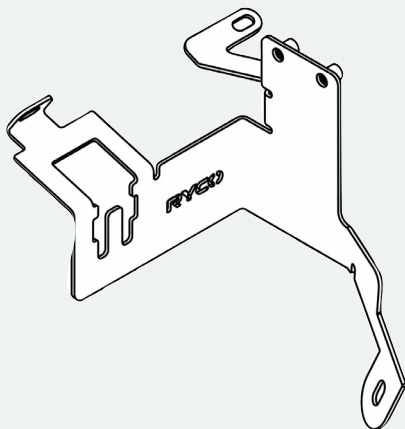

VOLKSWAGEN AMAROK 2.0L Turbo Diesel 1/2010 ..on - See RYCO catalogue for specific application details The Ryco X110R kit includes mounting bracket specifically designed for the vehicle, and all components required to complete the installation of Ryco Z980SK16 series fuel water separator and RCC360 series catch can. It is recommended that the installation is conducted by a qualified mechanic following the procedures in this instruction sheet.



SECTION 1
MOUNTING BRACKET



SECTION 2
FUEL WATER SEPARATOR

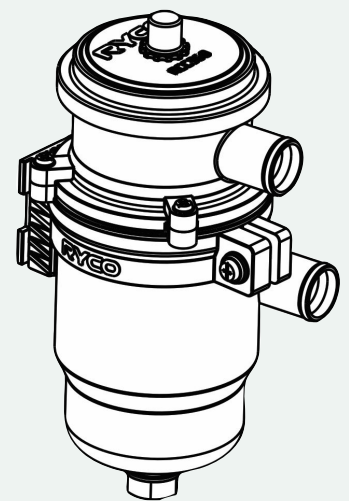

SECTION 3
CATCH CAN

COMPONENTS INCLUDED IN X110R KIT

PARTS LIST - BRACKET, FUEL FILTER & CATCHCAN COMPONENTS

FUEL WATER SEPARATOR MOUNTING POSITION

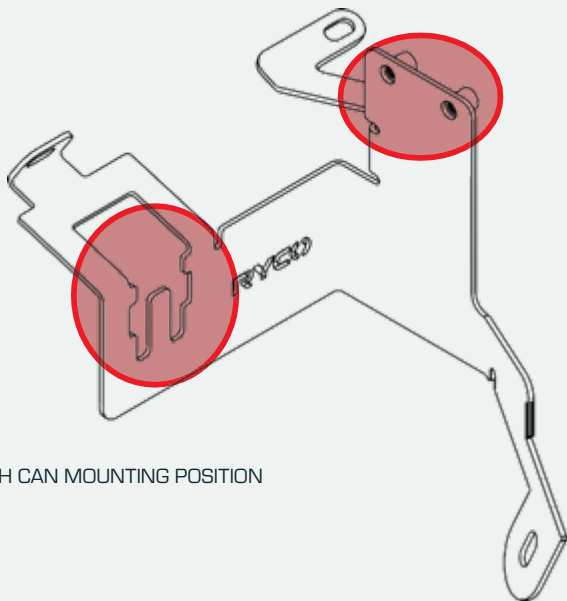

CATCH CAN MOUNTING POSITION

HF9807
FUEL HOSE x 2 (820mm)

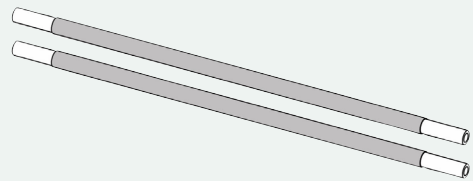

MF9807A
PCV HOSE x 1

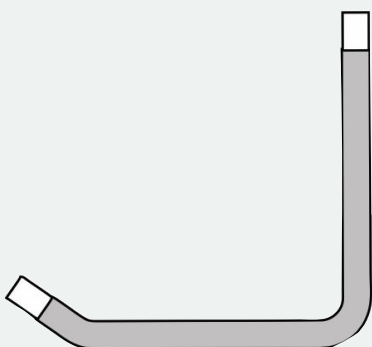

MF9807B
PCV HOSE x 1

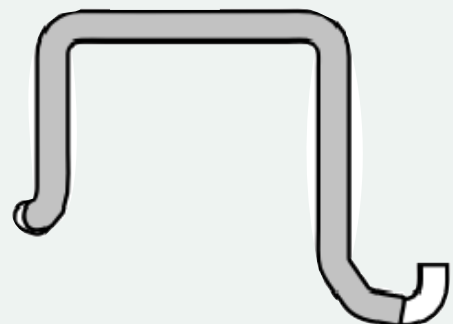

SECTION 1 MOUNTING BRACKET FITMENT

PARTS REQUIRED

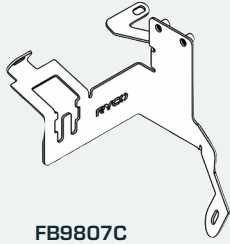

FB9807C
Fuel Mounting Bracket



MS4037
Hex Bolt (M6)

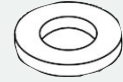

MS4106
Flat Washer (M8)

TOOLS & PPE REQUIRED

- Work Gloves
- Socket Set

WORK PROCEDURE

- 1 Unscrew the two factory flange bolts located at point B and C on Fig.1, page 6.
- 2 Position the bracket in the engine bay as per Fig. 1, page 6.
- 3 Install the supplied M6 bolt with washer at Point A, tighten loosely so that the bracket can be adjusted to the slots with the other points of attachment.
- 4 Install the factory flange bolts back into point B and C to clamp and secure the bracket.
- 5 Tighten all fasteners as per Fig. 2, page 6.

SECTION 1 MOUNTING BRACKET FITMENT

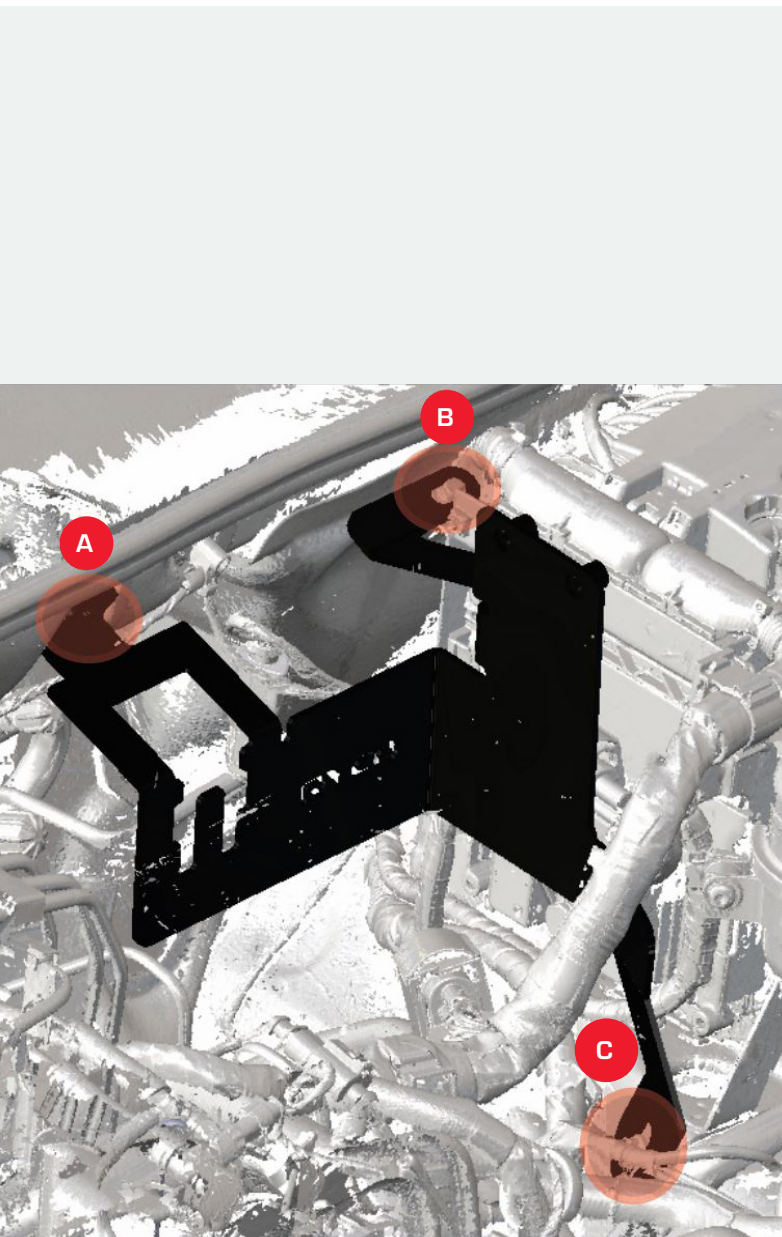

FIGURE 1
BRACKET IN ENGINE BAY



FIGURE 2A
ATTACHMENT POINTS



FIGURE 2B
ATTACHMENT POINTS



FIGURE 2C
ATTACHMENT POINTS

SECTION 2 FUEL WATER SEPARATOR INSTALLATION

PARTS REQUIRED

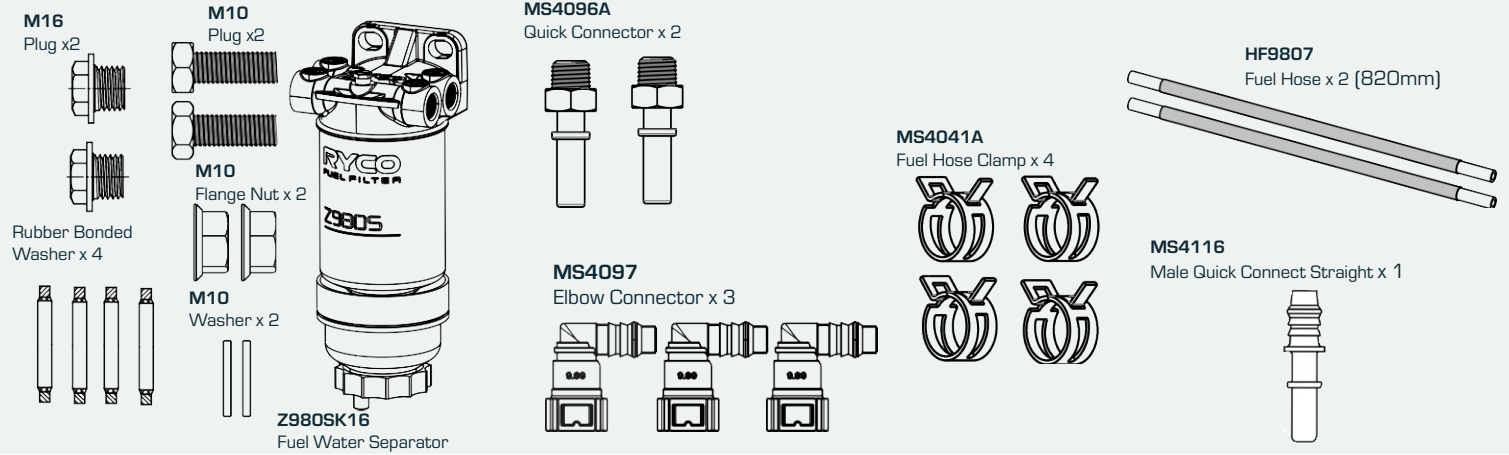

TOOLS & PPE REQUIRED

- Ratchet Set
- Work Gloves
- Hose Clamp Pliers
- Rags

WORK PROCEDURE

- 1 Select the supplied quick connectors that fit the Ryco fuel water separator head.
- 2 Locate the blanking plugs supplied with the fuel water separator.
- 3 Install the Ryco fuel water separator head with metal quick connectors, blanking plugs and rubber bonded washers, as per Fig 3. Tighten blanking plugs (on Port 3 & 4) and quick connectors (on Port 1 & 2).
- 4 Install two supplied elbow connectors onto one end of both supplied fuel hoses and install four supplied fuel hose clamps onto both ends of fuel hoses, as per Fig. 4. Do not tighten fuel hose clamps yet.

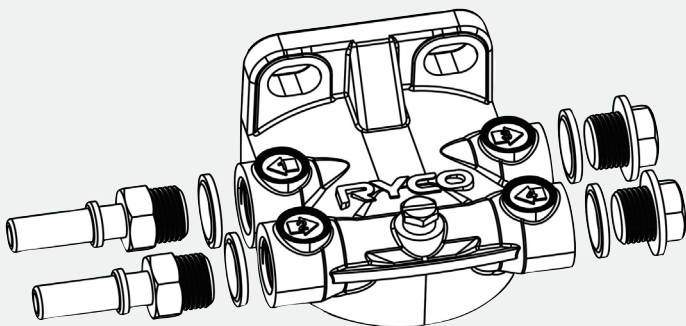

FIGURE 3
FUEL WATER SEPARATOR HEAD PREPARATION

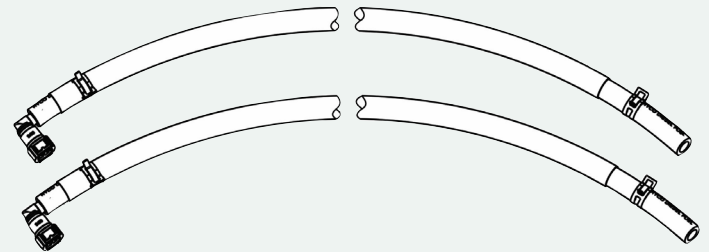

FIGURE 4
FUEL HOSE PREPARATION

SECTION 2 FUEL WATER SEPARATOR INSTALLATION

WORK PROCEDURE

- 1 Mount the Z980SK16 assembly onto the X110R mounting bracket using the two (2) black M10 bolts and M10 washers supplied with Z980SK16.
- 2 Connect one of the supplied fuel hoses to the inlet port of Z980SK16 (coloured red in Fig. 5) by pushing the elbow connector onto the metal quick connector until you hear a “click”, and route the other end straight down to reach the factory fuel supply pipe next to the factory fuel filter underneath the engine bay.
- 3 Connect the second hose to the outlet port of the Z980SK16 (coloured green in Fig. 5) by pushing the elbow connector onto the metal quick connector until you hear a “click”, and route the other end to reach the factory fuel filter similarly to Step. 2.
- 4 Tighten hose clamps and secure the two fuel hoses to the engine along the engine bay with the supplied cable ties.
- 5 Locate the factory fuel supply line by starting at the fuel inlet port of the factory fuel filter. Disconnect the fuel supply line from the factory filter, as per Fig. 6, page 9. Have a rag ready to capture any diesel that may spill out of the fuel line and the fuel filter. For final assembly of the fuel water separator and routing of the fuel hoses, see Fig. 6, page 9.

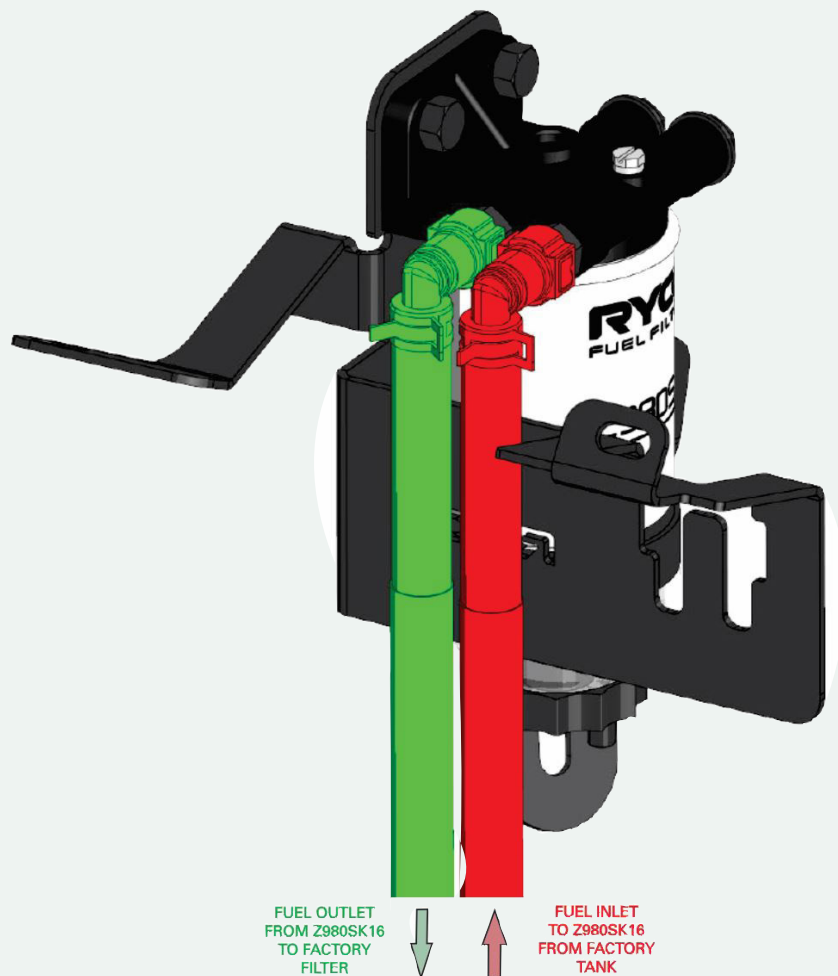

FIGURE 5
FUEL WATER SEPARATOR INSTALLATION

SECTION 2 FUEL WATER SEPARATOR INSTALLATION (CONTINUED)

FIGURE 6: STEP 1 - FUEL WATER SEPARATOR INSTALLATION AND FUEL HOSE ROUTING

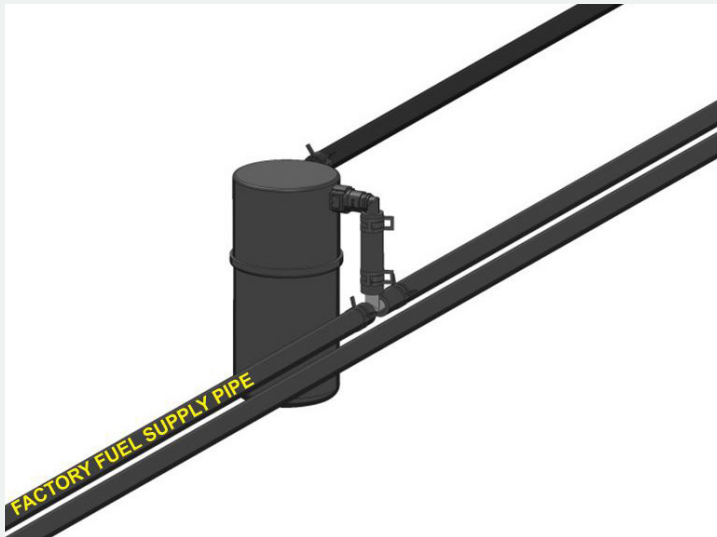

FIGURE 6: STEP 2

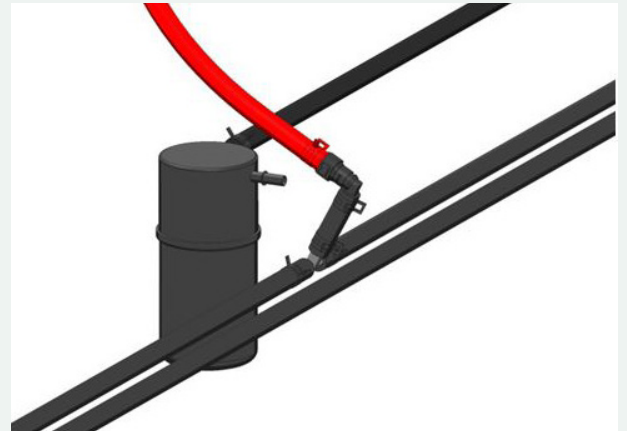
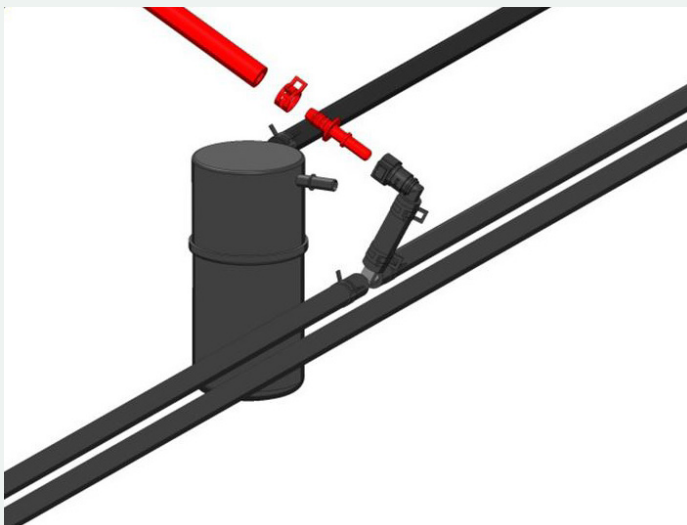

FIGURE 6: STEP 3

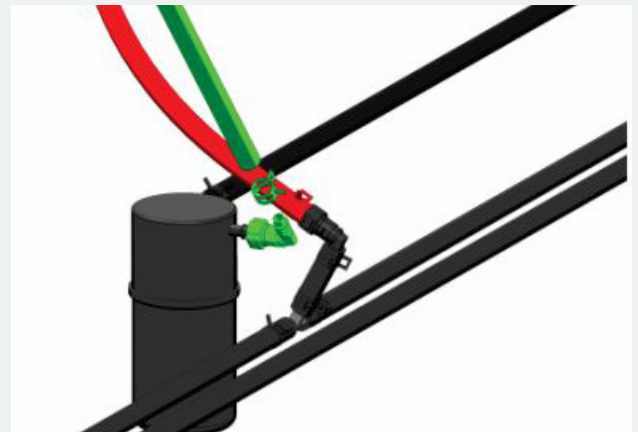

FIGURE 6: STEP 4

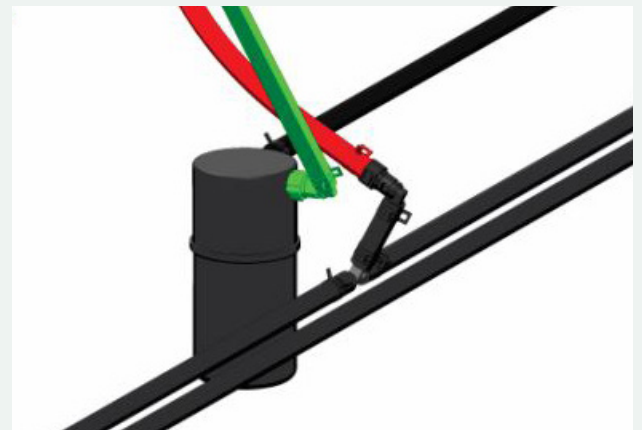
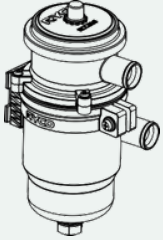

FIGURE 6: STEP 5

SECTION 3 CATCH CAN FITMENT

PARTS REQUIRED

RCC360
CATCH CAN



MF9807A
PCV Hose x 1

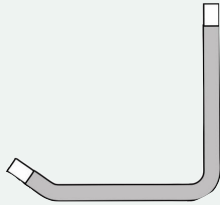

MF9807B
PCV Hose x 1

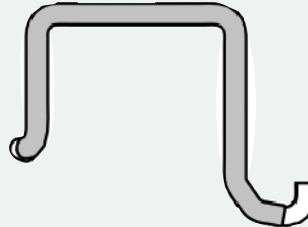

MS4091
PCV Hose Clamp x 4

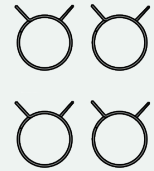

TOOLS & PPE REQUIRED

- Ratchet Set
- Work Gloves
- Socket Set

WORK PROCEDURE

- 1 Mount the catch can onto the bracket by sliding the RCC360 nylon bracket onto the catch can mounting position on FB9807C, rotate it so it is facing toward the front of the engine bay and tighten the plastic bracket retaining screw, as per Fig. 7.1.
- 2 Locate the factory PCV valve. Remove the factory rubber ventilation hose and store for safe keeping, as shown in Fig. 7.2.
- 3 Connect PCV hoses and secure with supplied clamps as shown in Fig. 7.3.

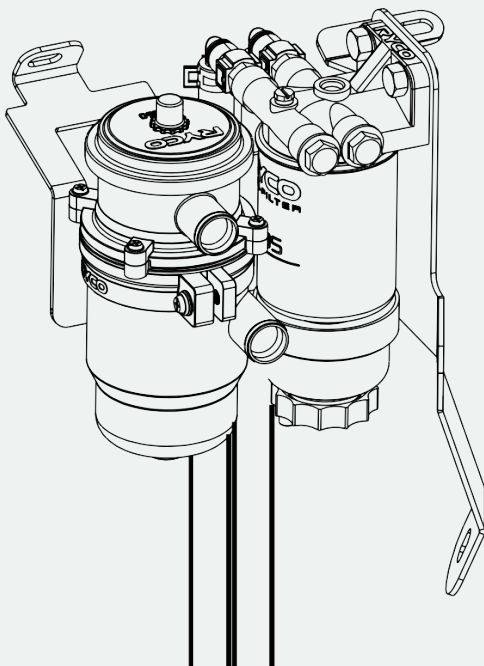

FIGURE 7.1

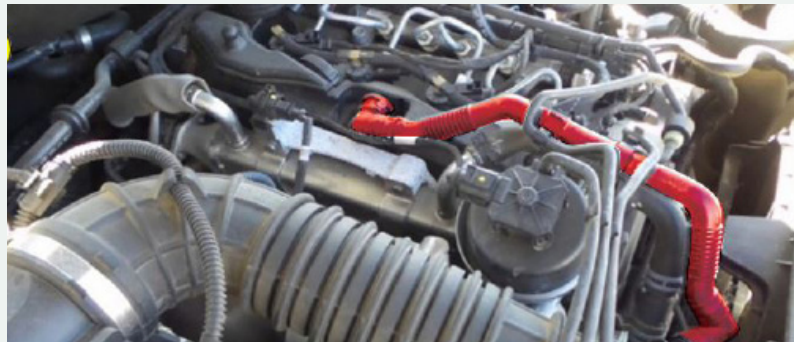

FIGURE 7.2

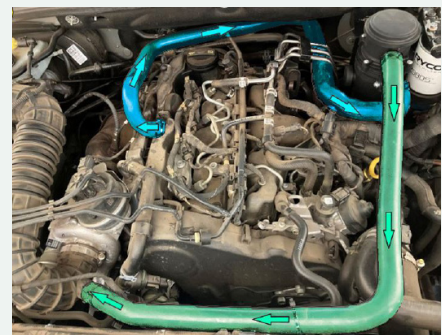
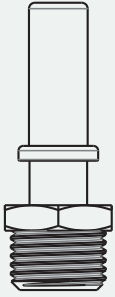
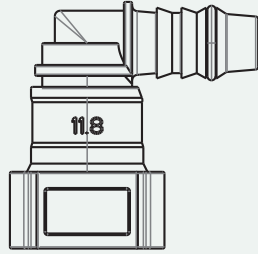

FIGURE 7.3

INCLUDED DRAIN HOSE COMPONENTS



MS4118
QUICK CONNECTOR x 1



MS4108
ELBOW QUICK CONNECTOR x 1

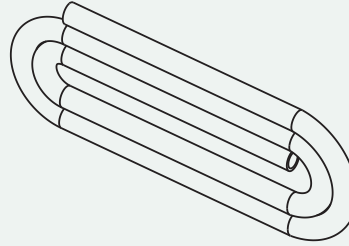

MS4117
PVC HOSE x 1M



MS4119 + MS4120
HOSE END PLUG x 1 SET

DRAIN HOSE INSTALLATION PROCEDURE

TO INSTALL THE DRAIN HOSE

- 1 Remove the blanking plug from the base of the catch can.
- 2 Remove the rubber washer from the blanking plug.
- 3 Fit rubber washer to the MS4118 Male Quick Connector.
- 4 Install MS4118 with rubber washer to the base of catch can.
- 5 Connect the MS4108 elbow female quick connector to the MS4118 male quick connector on the base of the catch can by pushing on until you hear a "click".
- 6 Insert the drain hose onto the barb end of MS4108 and secure with the supplied spring clamp.
- 7 Insert the MS4119 onto the other end of the hose and secure with the supplied spring clamp.
- 8 Use the zip ties to secure the hose.

INCLUDED DRAIN HOSE COMPONENTS

DRAIN HOSE INSTALLATION

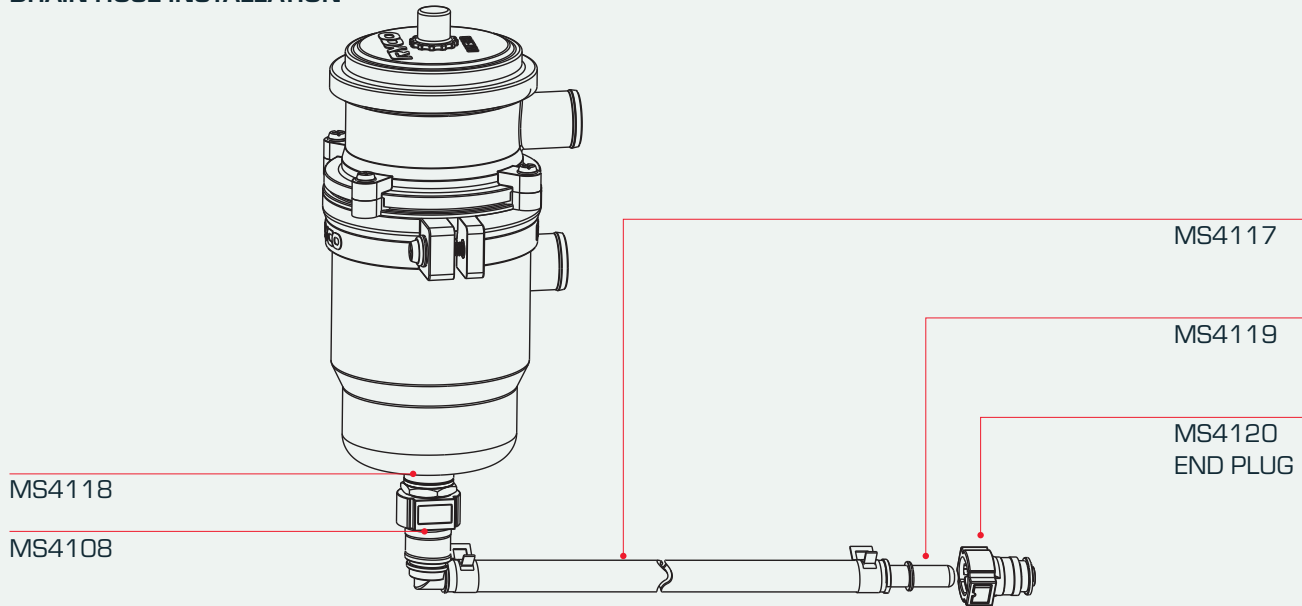

HOW TO DRAIN THE CATCH CAN

Note: Check the catch can sump level every month or 5000km, whichever comes first and drain as required. Sump level checks are recommended daily when four-wheel driving or towing.

IF THE DRAIN HOSE IS FITTED

- 1 Push both buttons on the MS4120 end plug and pull to separate from the MS4119.
- 2 Allow all oil to drain out.
- 3 Push MS4120 plug back on to MS4119 until you hear a “click”.

IF FITTED WITHOUT DRAIN HOSE

- 1 Slide catch can out of the bracket. You may need to remove inlet and outlet hoses by loosening the hose clamps.
- 2 Remove the blanking plug from the base of the catch can.
- 3 Allow all oil to drain.
- 4 Refit the blanking plug to the base of the catch can ensure the rubber seal is in place.

WHEN SHOULD YOU SERVICE THE CATCH CAN

CHECK SERVICE INDICATOR

If red service indicator is not raised, the catch can does not currently require a service. Check again in a month or 5000 km. Sump level checks are recommended daily when four-wheel driving or towing. If the red service indicator is raised, unscrew the clear service indicator housing and compress the red service indicator. Run the engine and if the red service indicator raises again, it is time to service your catch can.

NO SERVICE REQUIRED



SERVICE REQUIRED



HOW TO DRAIN THE CATCH CAN

- 1 Draining catch can before service is recommended.
- 2 Undo the four bolts the on catch can head, take note of outlet position. Remove hoses and clamps, if required.
- 3 Separate the head from the rest of the catch can.
- 4 Lift out old filter.
- 5 Use a rag to clean inside catch can sump.
- 6 Refit new filter (RCC160F), and replace the main housing o-ring.
- 7 Reinstall the filter head noting the position of the outlet port from earlier.
- 8 Tighten the four bolts and reinstall hoses and hose clamps if removed.

X110R™

X110R FUEL WATER SEPARATOR / CATCH CAN FITMENT INSTRUCTIONS